

DINGS'

Precision Motion Specialist

LINEAR MODULE PRODUCT CATALOG



Based on our company's platform product high-precision screw stepper motor, combined with linear guide rails, we have designed DLM series, LR-DLM series, DSM series, and DSLM series simple modules.

The product has a compact structure and high positioning accuracy, achieving mechanical miniaturization for customers. Both modules have a variety of lead screw and stroke options, providing accessories such as encoders and power brakes (refer to optional accessories for sliding screw linear actuators), as well as special customized products.

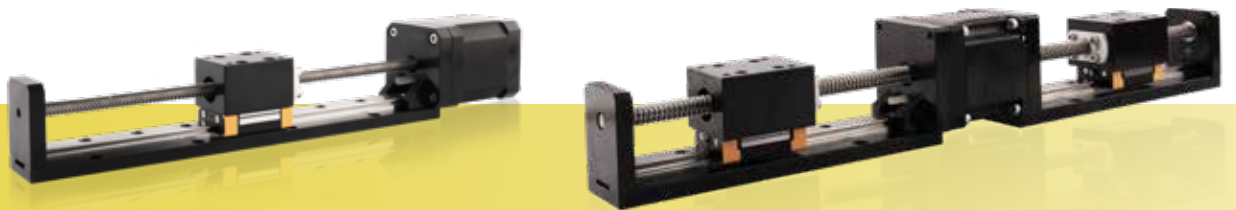

LINEAR MODULE SERIES

CONTENTS

DLM / LR-DLM series

DLM : Part number construction
LR-DLM : Part number construction
14 mm DLM
20 mm DLM / LR-DLM
28 mm DLM / LR-DLM
35 mm DLM / LR-DLM
42 mm DLM / LR-DLM
57 mm DLM / LR-DLM

DSM SERIES

Part number construction
14 mm
20 mm
28 mm
35 mm
42 mm

DSLMS SERIES

Part number construction
35 mm
42 mm
57 mm

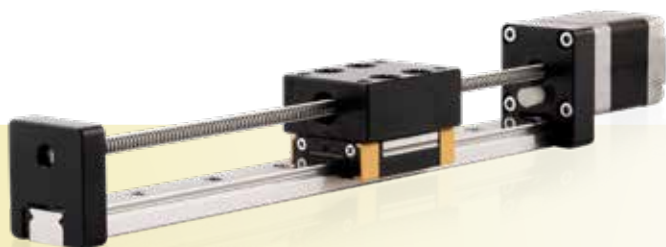

Part Number Construction - DLM Series

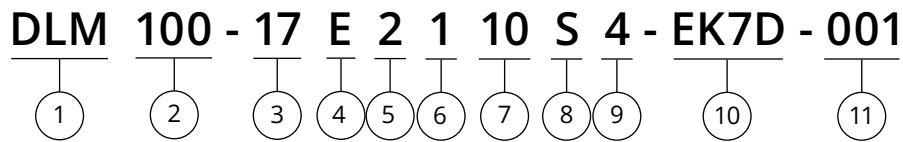

- | | | | | | | | | | | | | | | | |
|--|-----------------|----|----|----|----|----|----|-------------------|---|---|----|----|----|----|--|
| <p>① Product Name
DLM Series Module</p> <p>② Stroke (mm)
100 = 100mm</p> <p>③ Motor Size</p> <table border="1" style="margin-left: 20px;"> <tr> <td>Motor Size (mm)</td> <td>14</td> <td>20</td> <td>28</td> <td>35</td> <td>42</td> <td>57</td> </tr> <tr> <td>Motor Size (NEMA)</td> <td>6</td> <td>8</td> <td>11</td> <td>14</td> <td>17</td> <td>23</td> </tr> </table> <p>④ Motor Type
E = External type
N = Non-Captive type</p> <p>⑤ Motor Step Angle
2 = 2 Phase with 1.8°
4 = 2 Phase with 0.9°</p> <p>⑥ Motor Length
1 = Single stack
2 = Double stack</p> | Motor Size (mm) | 14 | 20 | 28 | 35 | 42 | 57 | Motor Size (NEMA) | 6 | 8 | 11 | 14 | 17 | 23 | <p>⑦ Rated Current / Phase
XX = X.X (A) / Phase</p> <p>⑧ Lead Screw Code
Please refer to lead screw code selection table</p> <p>⑨ Number of Lead Wires
4 = 4 Flying leads
6 = 6 Flying leads</p> <p>⑩ Option
EKX = Encoder [X = Encoder Resolution]
P = Manual Knob
B = Brake
X = Rear Shaft
R = Encoder Ready
C = Customize
N = No processing at the rear end</p> <p>⑪ Customer Sequence Number</p> |
| Motor Size (mm) | 14 | 20 | 28 | 35 | 42 | 57 | | | | | | | | | |
| Motor Size (NEMA) | 6 | 8 | 11 | 14 | 17 | 23 | | | | | | | | | |

Example

Part Number	DLM100-17E2110S4-EK7D-001
Description	<p>DLM Linear Module</p> <p>100mm Stroke</p> <p>NEMA 17 External Linear Actuator</p> <p>2 Phase / 1.8° Stepper</p> <p>Single Stack</p> <p>1.0A / Phase</p> <p>S Lead (0.25" or 6.35mm)</p> <p>4 Flying Wires</p> <p>EK7D Encoder with differential output 1,000 lines</p> <p>Serial Number 001</p>

Part Number Construction - L·R DLM

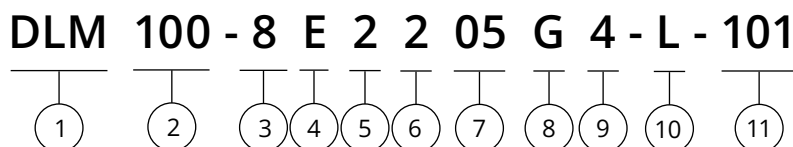

- ① Product Name
LR DLM Series Module
- ② Stroke (mm)
100 = 100mm
- ③ Motor Size

Motor Size (mm)	20	28	35	42	57
Motor Size (NEMA)	8	11	14	17	23
- ④ Motor Type
E = External type
- ⑤ Motor Step Angle
2 = 2 Phase with 1.8°
4 = 2 Phase with 0.9°
- ⑥ Motor Length
1 = Single stack
2 = Double stack
- ⑦ Rated Current / Phase
XX = X.X (A) / Phase
- ⑧ Lead Screw Code
Please refer to lead screw code selection table
- ⑨ Number of Lead Wires
4 = 4 Flying leads
6 = 6 Flying leads
- ⑩ LR DLM
The notation "L" stands for LR DLM
- ⑪ Customer Sequence Number

Example

Part Number	DLM100-8E2205G4-L-101
Description	LR DLM Linear Module 100mm Stroke NEMA 8 External Linear Actuator 2 Phase / 1.8° Stepper Double Stack 1.0A / Phase G Lead (0.0787" or 2.0mm) 4 Flying Wires LR DLM Serial Number 001

Size 14mm DLM

Based on DINGS' platform products, high precision of lead screw linear actuator and self-developed simple linear module, DLM 14mm series is compact and reliable structure of linear solution.

DLM 14mm Series is good precision, high diversity of optional stroke and lead based customization linear module which can provide customers with integrated customization solutions.



Motor Characteristics

Motor	Voltage (V)	Current (A _{RMS})	Resistance (Ω)	Inductance (mH)	Weight (g)	Lead Wire No.	Motor Length (mm)
6-2103	6.6	0.3	22	4.5	60	4	32

Available Lead Screw and Travel per Step

Screw Dia. (inch)	Screw Dia. (mm)	Lead (inch)	Lead (mm)	Lead Code	Travel Per Step @1.8° (mm)*
0.138	3.5	0.0118	0.3	AF	0.0015
0.138	3.5	0.024	0.6096	AA	0.003048
0.138	2.5	0.0394	1	AB	0.005
0.138	3.5	0.048	1.2192	B	0.006096
0.138	3.5	0.0787	2	G	0.01
0.138	3.5	0.1575	4	M	0.02
0.138	3.5	0.315	8	T	0.04

Size 14mm DLM

Dimensional Drawings

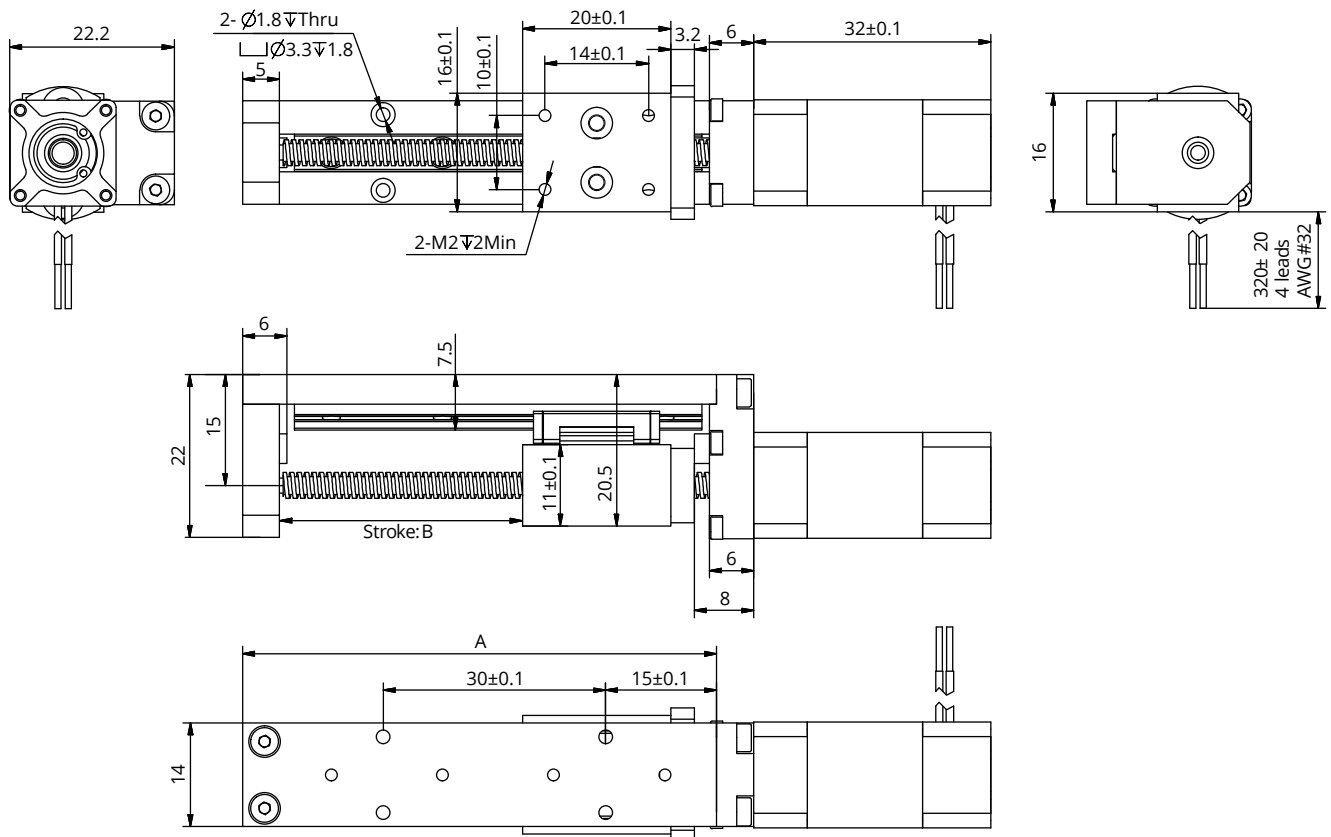

Available Stroke Selection

Size A (mm)	Stroke B (mm)
60	20
80	40
100	60
120	80
140	100

Size 14mm DLM

Speed Thrust Curves

Size 6 Single Stack Speed Thrust Curves

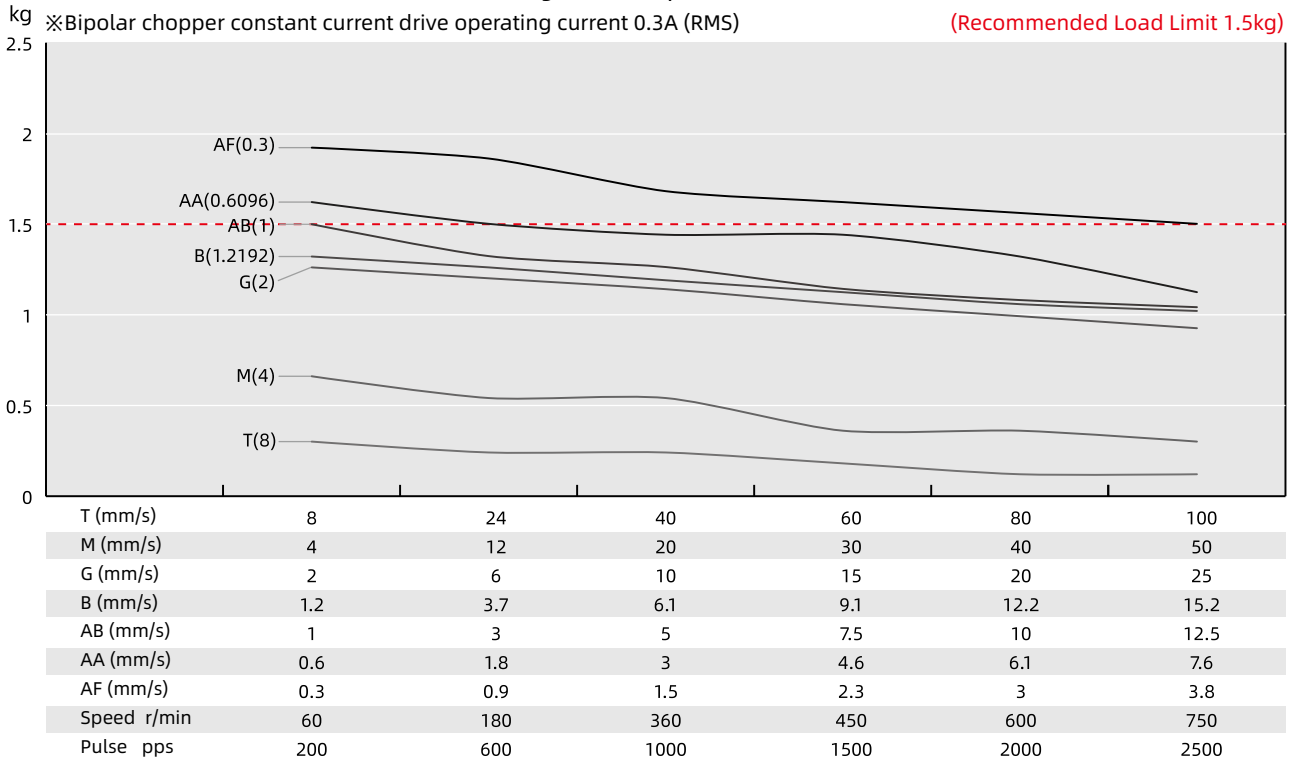

TEST CONDITION

Testing Voltage: 24Vdc, Driver Model: DS-OLS2-FPD bipolar, chopper driver at rated current (rms).
Motor's thrust will be changed with different voltage and driver. 50% thrust margin is recommended.

Size 20mm DLM / L·R DLM

Based on DINGS' platform products, high precision of lead screw linear actuator and self-developed simple linear module, DLM and LR-DLM 20mm series are compact and reliable linear solution structures.

DLM and LR-DLM 20mm series offer good precision, a high diversity of optional strokes, and lead-based customization. These linear modules can provide customers with integrated, customized solutions.

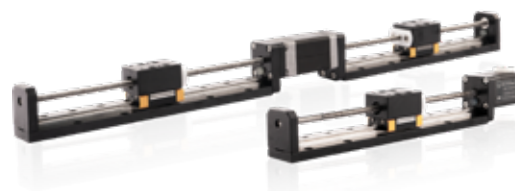

Motor Characteristics

Motor	Voltage (V)	Current (A _{RMS})	Resistance (Ω)	Inductance (mH)	Lead wire No.	Motor length (mm)
8E2105	2.5	0.5	5.1	1.5	4	27.2
8E2205	4.4	0.5	8.8	2.7	4	38.1

Available Lead Screw and Travel per Step

Screw Dia. (inch)	Screw Dia. (mm)	Lead (inch)	Lead (mm)	Lead Code	Travel Per Step @1.8° (mm)*
0.138	3.5	0.0118	0.3	AF	0.0015
0.138	3.5	0.024	0.6096	AA	0.003048
0.138	3.5	0.0394	1	AB	0.005
0.138	3.5	0.048	1.2192	B	0.006096
0.138	3.5	0.0787	2	G*	0.01
0.138	3.5	0.1575	4	M	0.02
0.138	3.5	0.315	8	T	0.04

* Lead code G is only available for LR-DLM 20mm

Mechanical Specifications

Model	C100B(dyn)(N)	Co(stat)(N)	Mro(Nm)	Mpo(Nm)	Myo(Nm)
DLM / L·R DLM 20	445	720	2.6	1.65	1.65

Size 20mm DLM / L·R DLM

Dimensional Drawings

20mm DLM

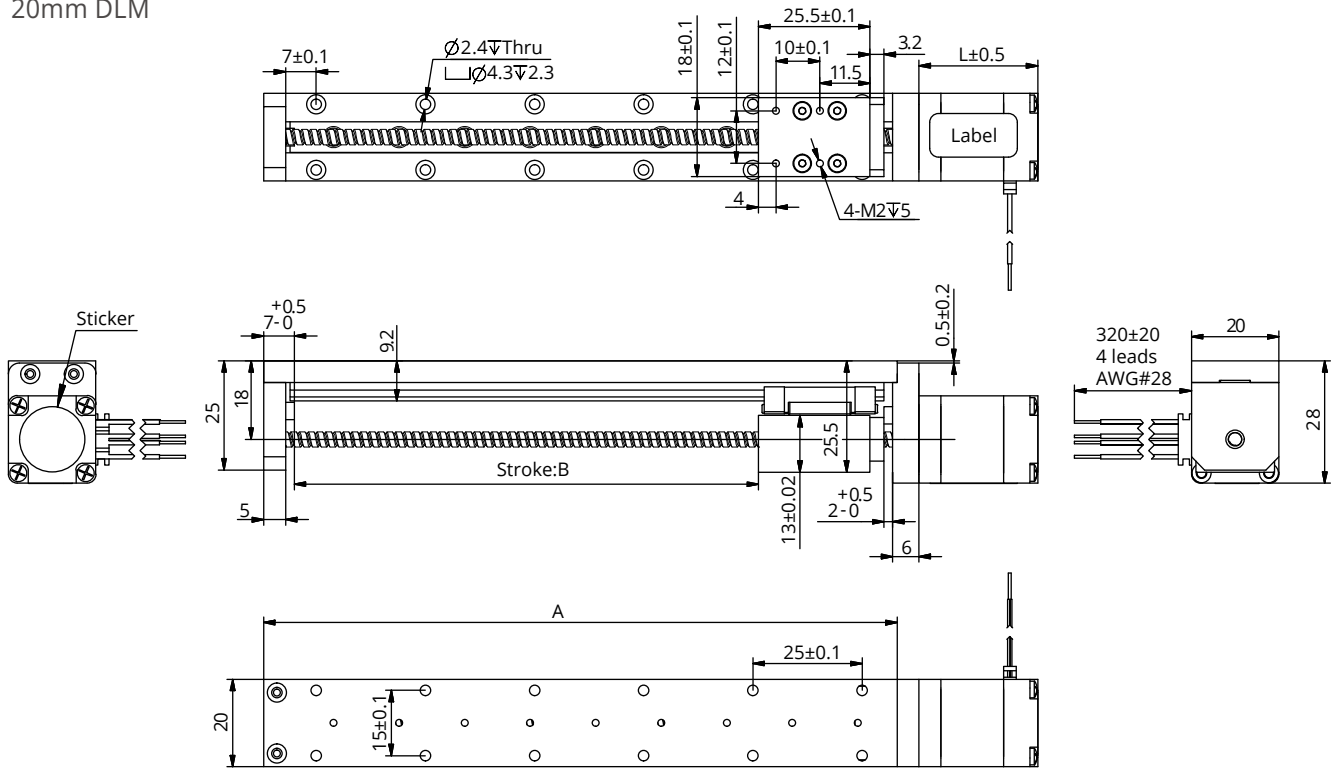

Available Stroke Selection

Size A (mm)	Stroke B (mm)
60	20
80	40
100	60
120	80
140	100
190	150
240	200

Size 20mm DLM / L·R DLM

● 20mm L·R DLM

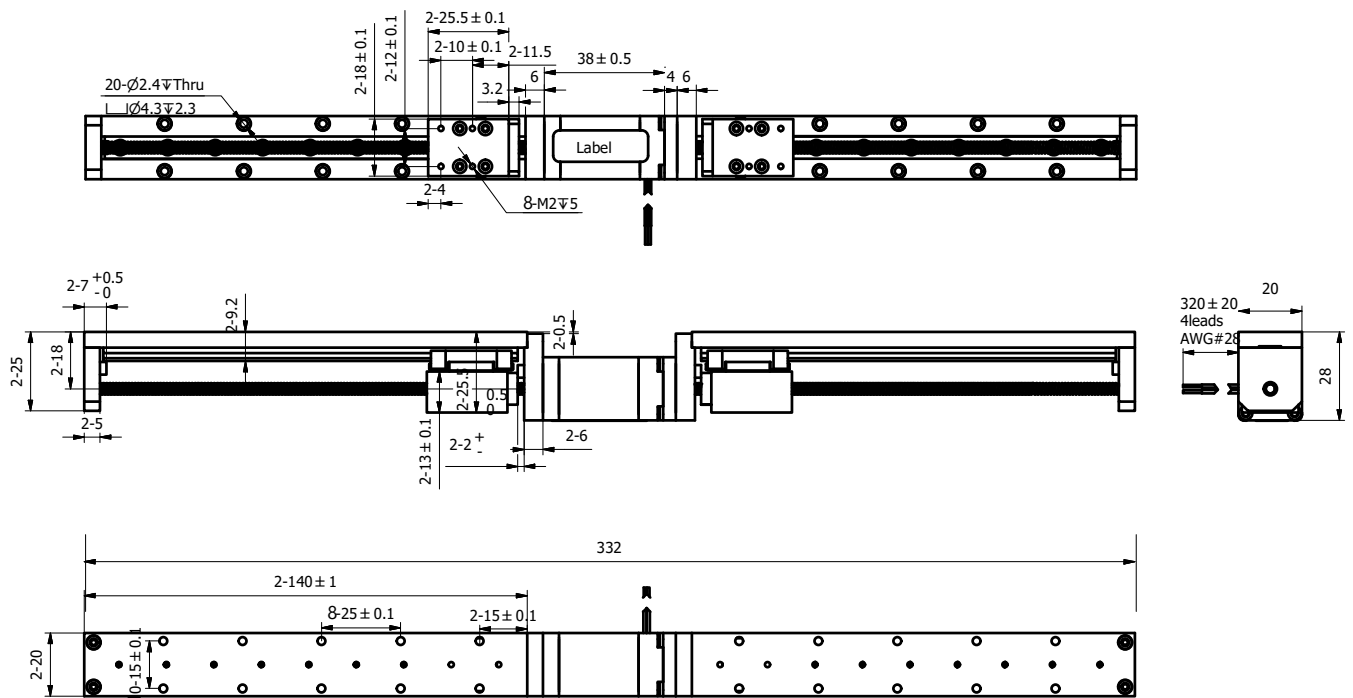

● Available Stroke Selection

Stroke (mm)	Total length (Dual motor-mm)
20	172
40	212
60	252
80	292
100	332
150	432
200	532

Note : All drawings are 1st Angle Projection - ISO Compliant (3D models available)

Size 20mm DLM / L·R DLM

Speed Thrust Curves

Size 8 Single Stack Speed Thrust Curves

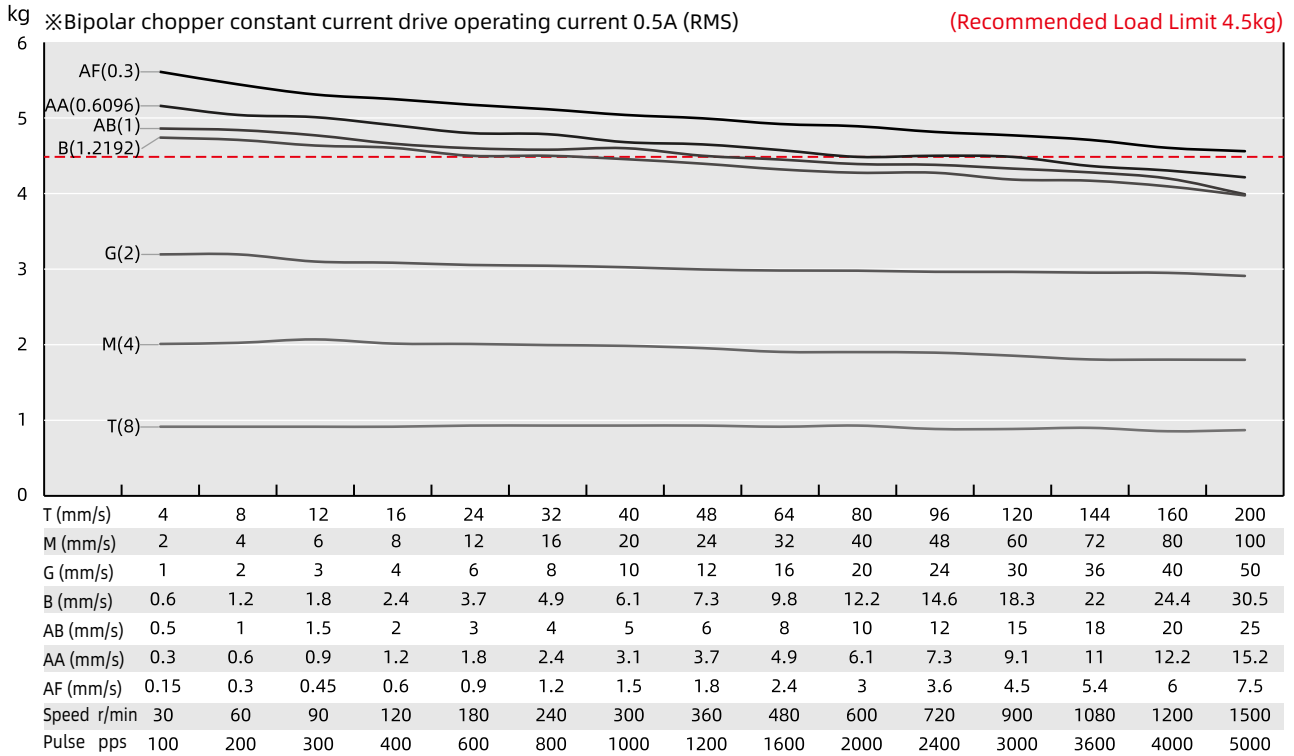

Size 8 Double Stack Speed Thrust Curves

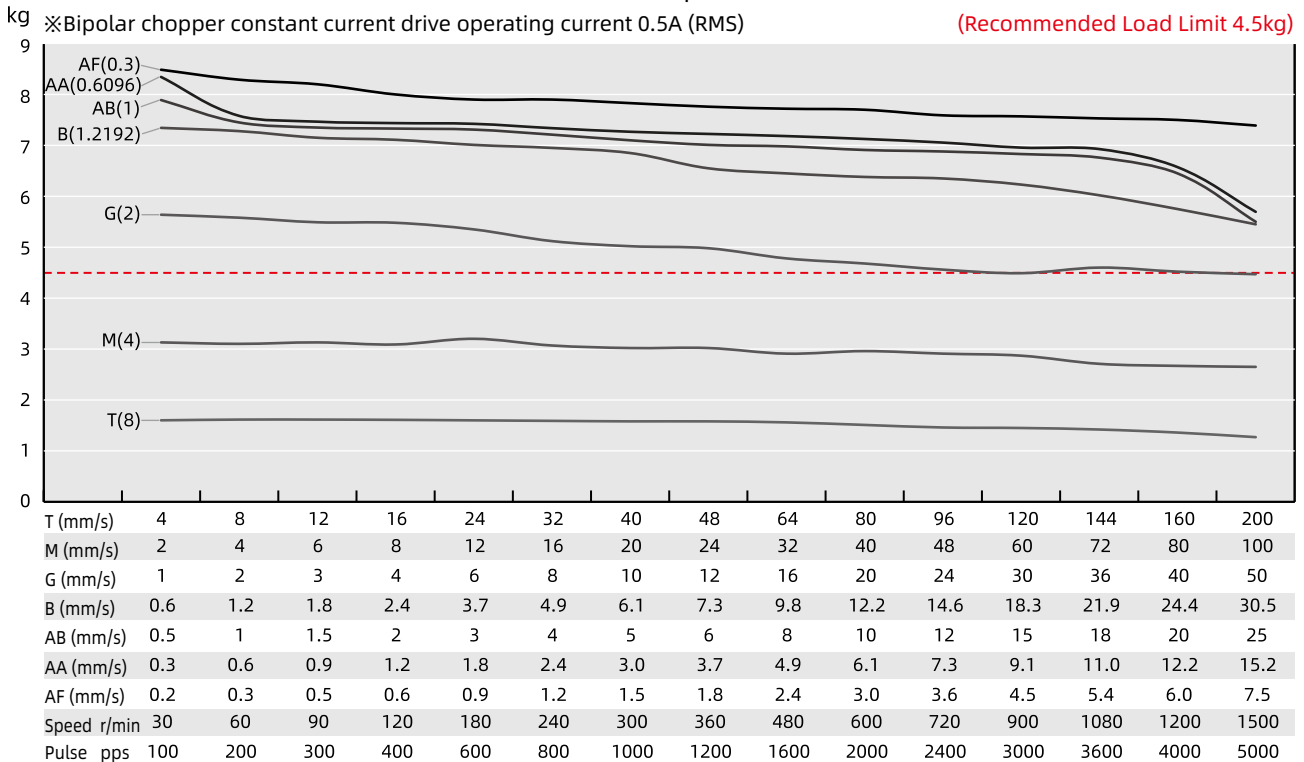

TEST CONDITION

Testing Voltage: 24Vdc, Driver Model: DS-OLS2-FPD bipolar, chopper driver at rated current (rms).
Motor's thrust will be changed with different voltage and driver. 50% thrust margin is recommended.

Size 28mm DLM / L·R DLM

Based on DINGS' platform products, high precision of lead screw linear actuator and self-developed simple linear module, DLM and LR-DLM 28mm series are compact and reliable linear solution structures.

DLM and LR-DLM 28mm series offer good precision, a high diversity of optional strokes, and lead-based customization. These linear modules can provide customers with integrated, customized solutions.



Motor Characteristics

Motor	Voltage (V)	Current (A [RMS])	Resistance (Ω)	Inductance (mH)	Lead wire No.	Motor length (mm)
11E2105	4.55	0.5	9.1	6.0	4	33.35
11E2110	2.1	1.0	2.1	1.5	4	33.35
11E2209	3.9	0.95	4.1	4.0	4	45
11E2216	2.4	1.6	1.5	1.3	4	45

Available Lead Screw and Travel per Step

Screw Dia. (inch)	Screw Dia. (mm)	Lead (inch)	Lead (mm)	Lead Code	Travel Per Step @1.8° (mm)*
0.188	4.77	0.0125	0.3175	AL	0.0016
0.188	4.77	0.025	0.635	A	0.003175
0.188	4.77	0.05	1.27	D*	0.00635
0.188	4.77	0.1	2.54	K	0.0127
0.188	4.77	0.2	5.08	R	0.0254
0.188	4.77	0.4	10.16	X	0.0508

* Lead code D is only available for LR-DLM 28mm

Mechanical Specifications

Model	C100B(dyn)(N)	Co(stat)(N)	Mro(Nm)	Mpo(Nm)	Myo(Nm)
DLM / L·R DLM 28	445	720	2.6	1.65	1.65

Size 28mm DLM / L·R DLM

Dimensional Drawings

28mm DLM

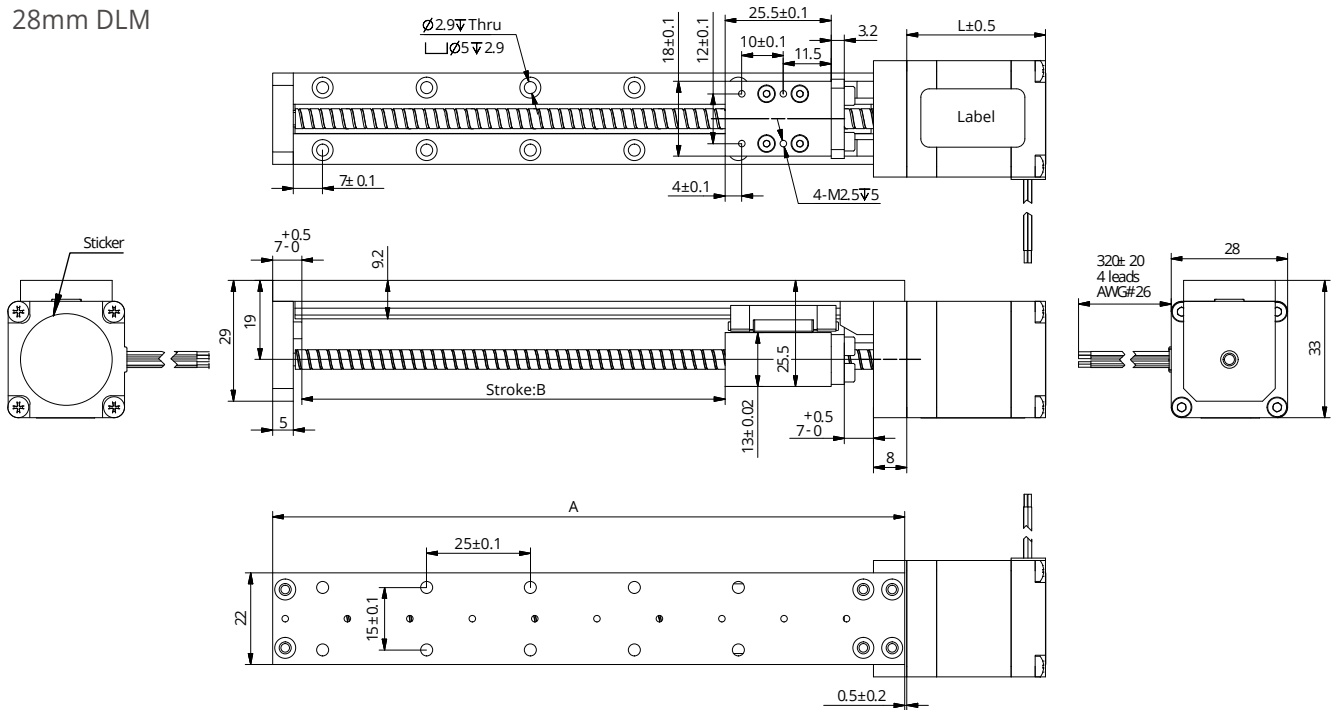

Available Stroke Selection

Size A (mm)	Stroke B (mm)
72	20
92	40
112	60
132	80
152	100
202	150
252	200
302	250
352	300

Size 28mm DLM / L·R DLM

- 28mm L·R DLM

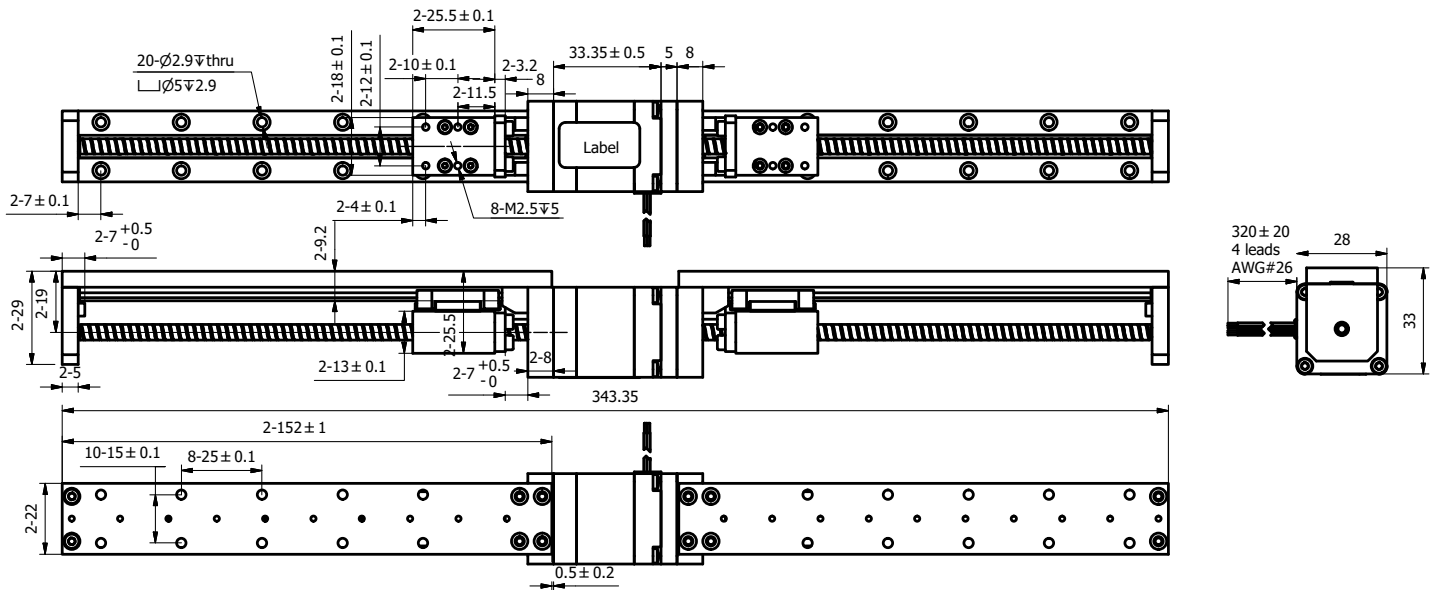

- Available Stroke Selection

Stroke (mm)	Total length (Dual motor-mm)
20	183.5
40	223.5
60	263.5
80	303.5
100	343.5
150	443.5
200	543.5

Size 28mm DLM / L·R DLM

Speed Thrust Curves

Size 11 Single Stack Speed Thrust Curves

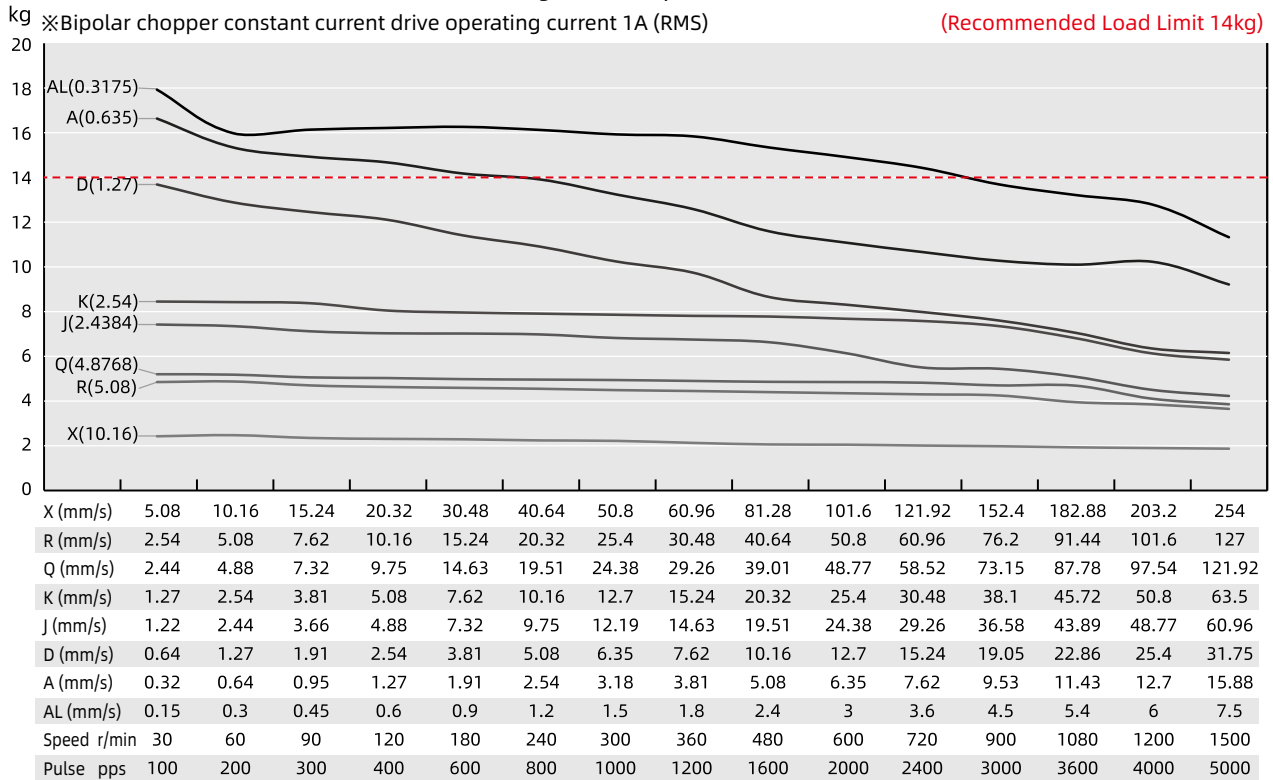

Size 11 Double Stack Speed Thrust Curves

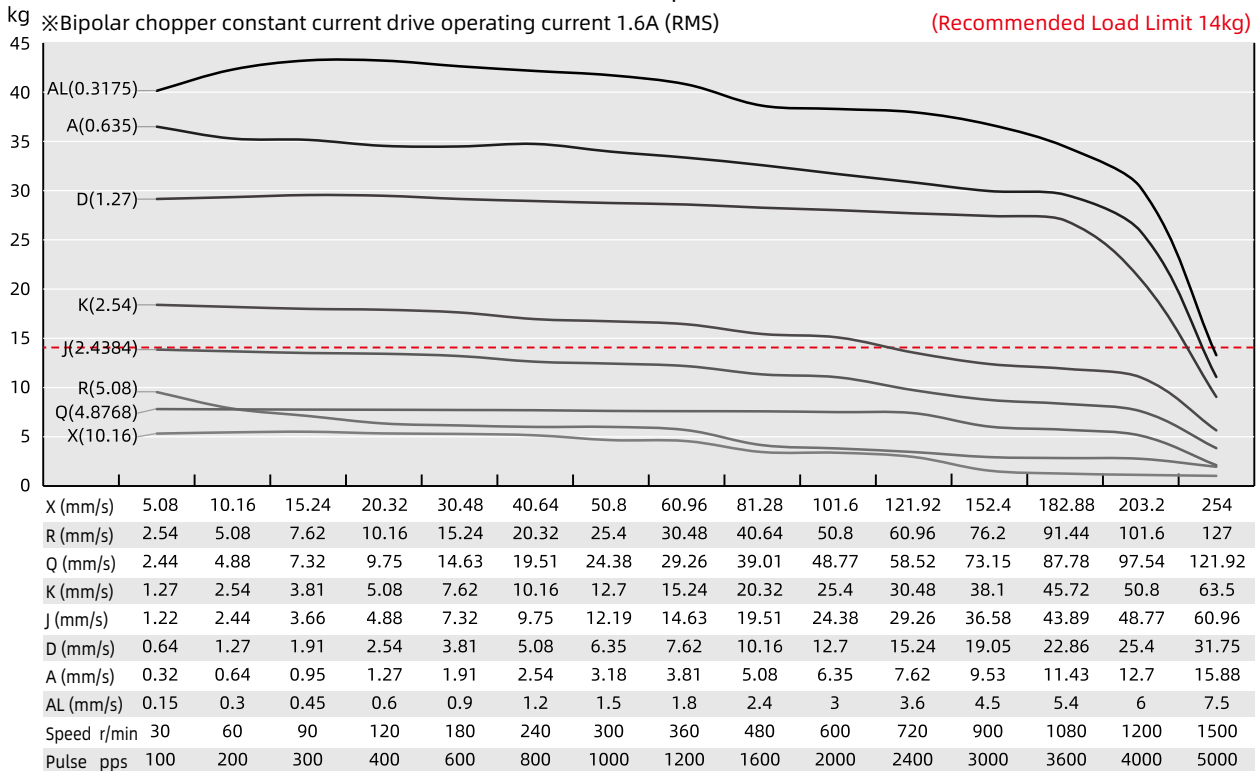

TEST CONDITION

Testing Voltage: 24Vdc, Driver Model: DS-OLS2-FPD bipolar, chopper driver at rated current (rms).

Motor's thrust will be changed with different voltage and driver. 50% thrust margin is recommended.

Size 35mm DLM / L·R DLM

Based on DINGS' platform products, high precision of lead screw linear actuator and self-developed simple linear module, DLM and LR-DLM 35mm series are compact and reliable linear solution structures.

DLM and LR-DLM 35mm series offer good precision, a high diversity of optional strokes, and lead-based customization. These linear modules can provide customers with integrated, customized solutions.



Motor Characteristics

Motor	Voltage (V)	Current (A _{RMS})	Resistance (Ω)	Inductance (mH)	Lead wire No.	Motor length (mm)
14E2105	6.6	0.5	13.2	14	4	33.6
14E2110	3.5	1.0	3.5	3.6	4	33.6
14E2115	2.7	1.5	1.8	1.9	4	33.6
14E2205	12.0	0.5	24.0	29	4	45.6
14E2210	6.0	1.0	6.0	7.2	4	45.6
14E2215	4.0	1.5	2.7	3.2	4	45.6

Available Lead Screw and Travel per Step

Screw Dia. (inch)	Screw Dia. (mm)	Lead (inch)	Lead (mm)	Lead Code	Travel Per Step @1.8° (mm)*
0.25	6.35	0.024	0.6096	AA	0.003048
0.25	6.35	0.0394	1	AB	0.005
0.25	6.35	0.048	1.2192	B	0.006096
0.25	6.35	0.05	1.27	D	0.00635
0.25	6.35	0.0625	1.5875	F*	0.0079
0.25	6.35	0.096	2.4384	J	0.0122
0.25	6.35	0.1	2.54	K	0.0127
0.25	6.35	0.125	3.175	L	0.0159
0.25	6.35	0.192	4.8768	Q	0.024
0.25	6.35	0.2	5.08	R	0.0254
0.25	6.35	0.25	6.35	S	0.0318
0.25	6.35	0.333	8.4667	U	0.0423
0.25	6.35	0.384	9.7536	W	0.0488
0.25	6.35	0.5	12.7	Y	0.0635
0.25	6.35	1	25.4	Z	0.127
0.31	8	0.1575	4	M	0.02
0.31	8	0.315	8	T	0.04
0.31	8	0.0787	2	G	0.01

* Lead code F is only available for LR-DLM 35mm

Size 35mm DLM / L·R DLM

Mechanical Specifications

Model	C100B(dyn)(N)	Co(stat)(N)	Mro(Nm)	Mpo(Nm)	Myo(Nm)
DLM / L·R DLM 35	445	720	2.66	1.65	1.65

Dimensional Drawings

35mm DLM

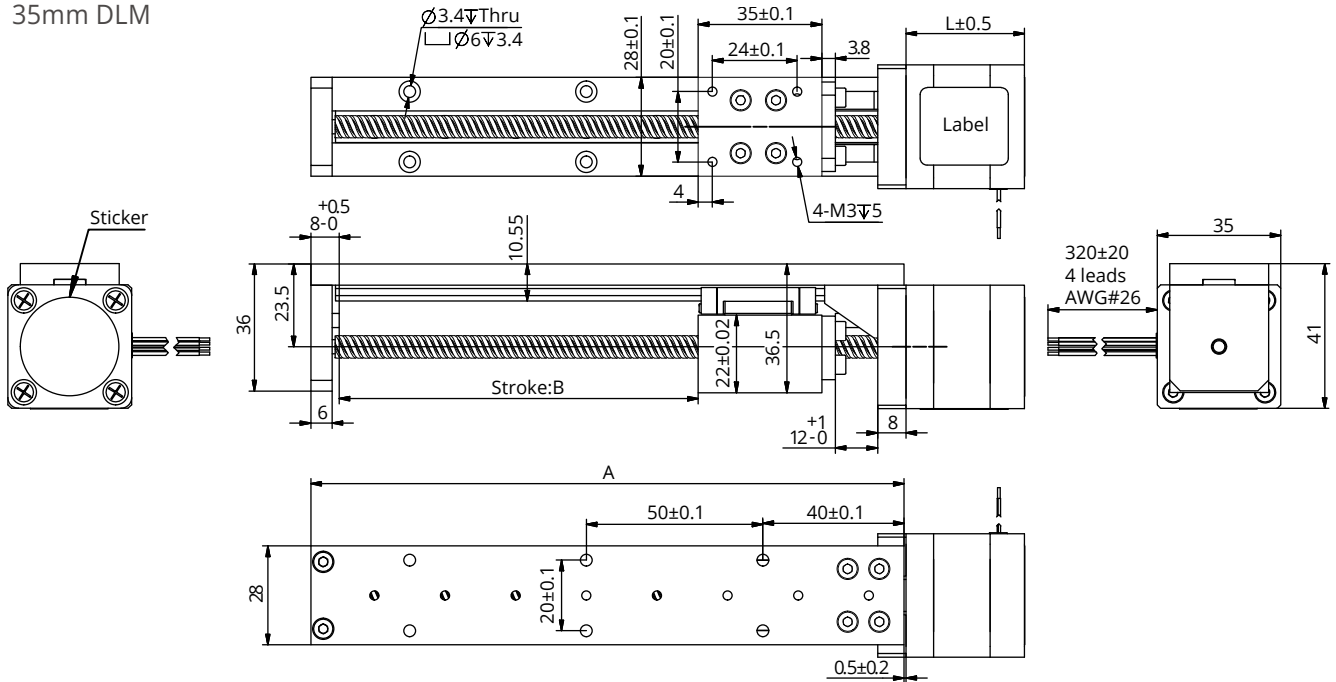

Available Stroke Selection

Size A (mm)	Stroke B (mm)
118	50
168	100
218	150
268	200
318	250
368	300
418	350
468	400
518	450
568	500

● 35mm L-R DLM

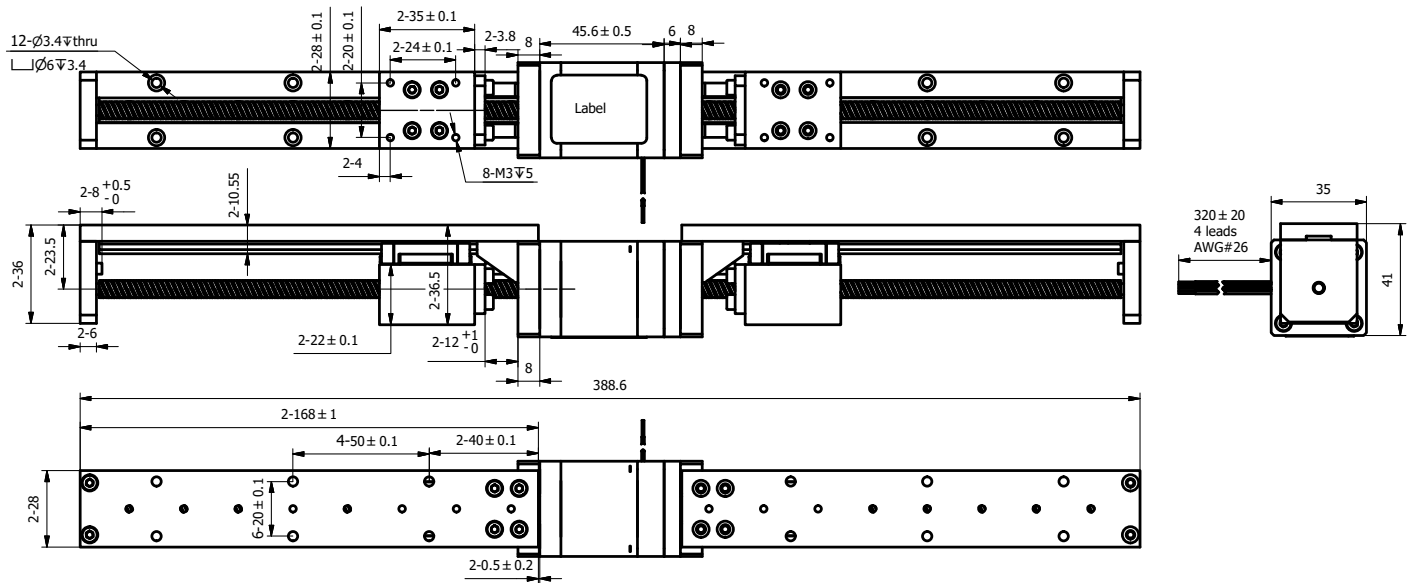

● Available Stroke Selection

Stroke (mm)	Total length (Dual motor-mm)
50	288.6
100	388.6
150	488.6
200	588.6
250	688.6
300	788.6
350	888.6
400	988.6

Note : All drawings are 1st Angle Projection - ISO Compliant (3D models available)

Speed Thrust Curves

Size 14 Single Stack Speed Thrust Curves

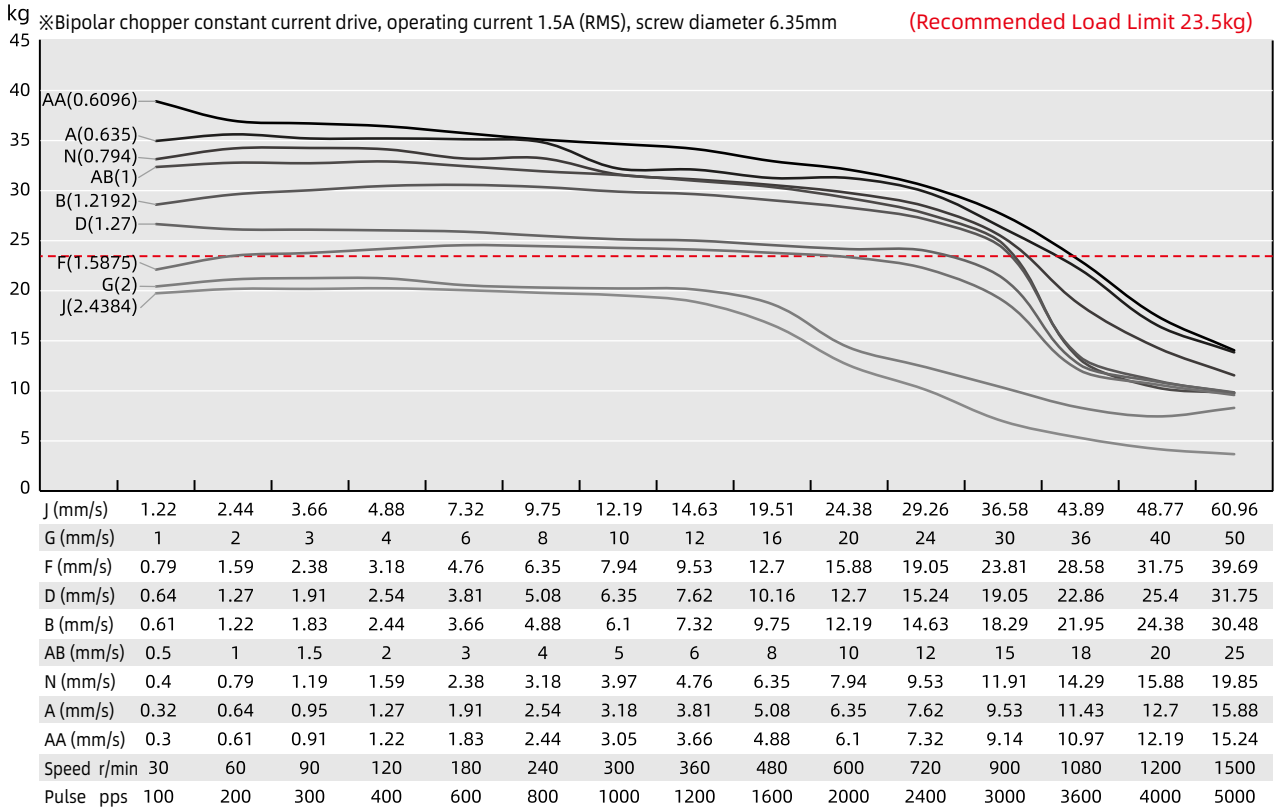

Size 14 Single Stack Speed Thrust Curves

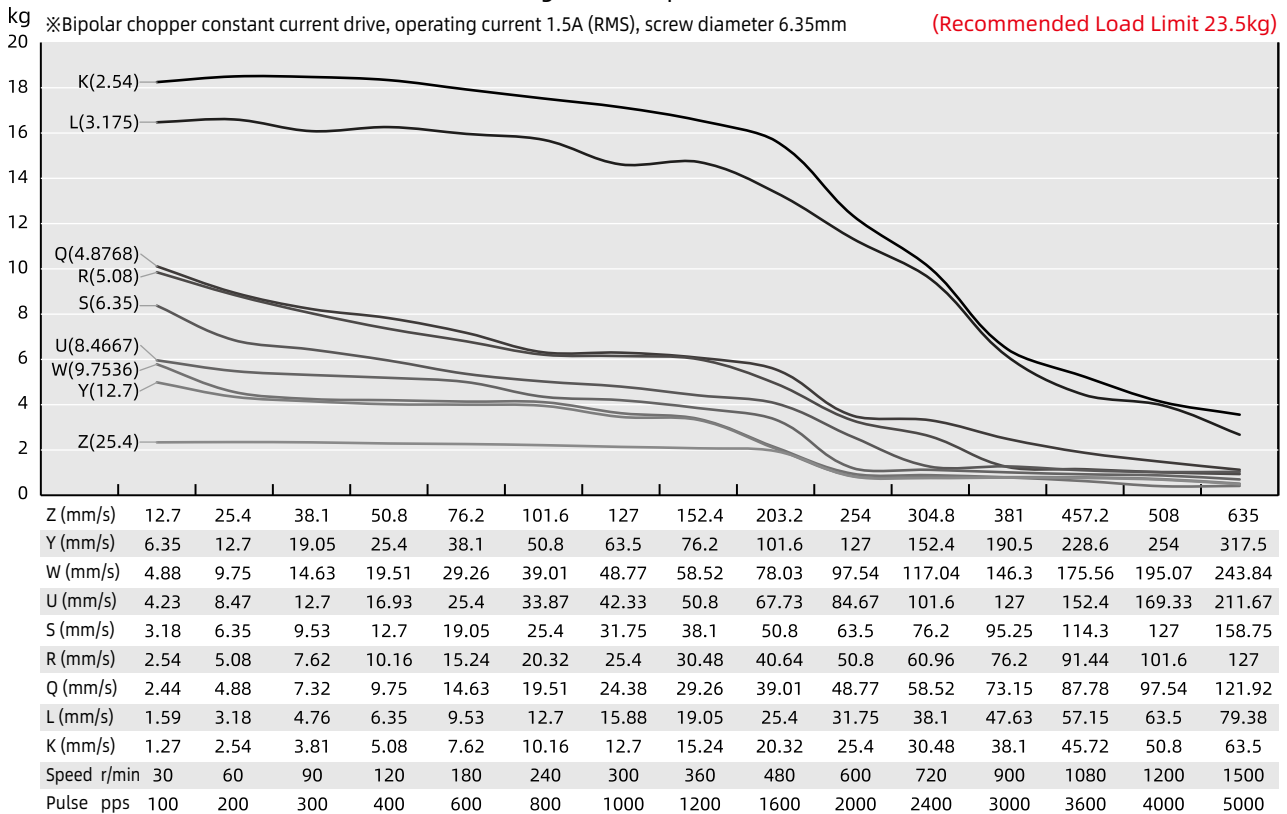

TEST CONDITION

Testing Voltage: 24Vdc, Driver Model: DS-OLS2-FPD bipolar, chopper driver at rated current (rms).
Motor's thrust will be changed with different voltage and driver. 50% thrust margin is recommended.

Size 14 Single Stack Speed Thrust Curves

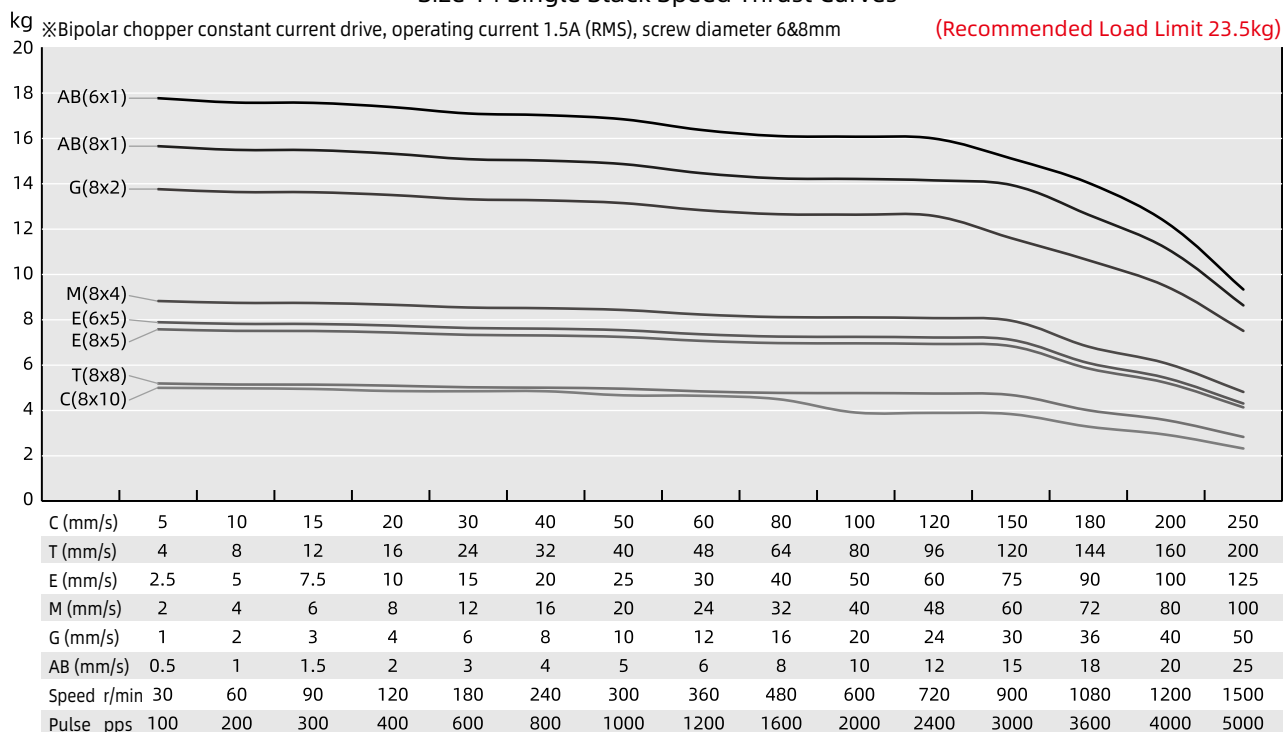

Size 14 Double Stack Speed Thrust Curves

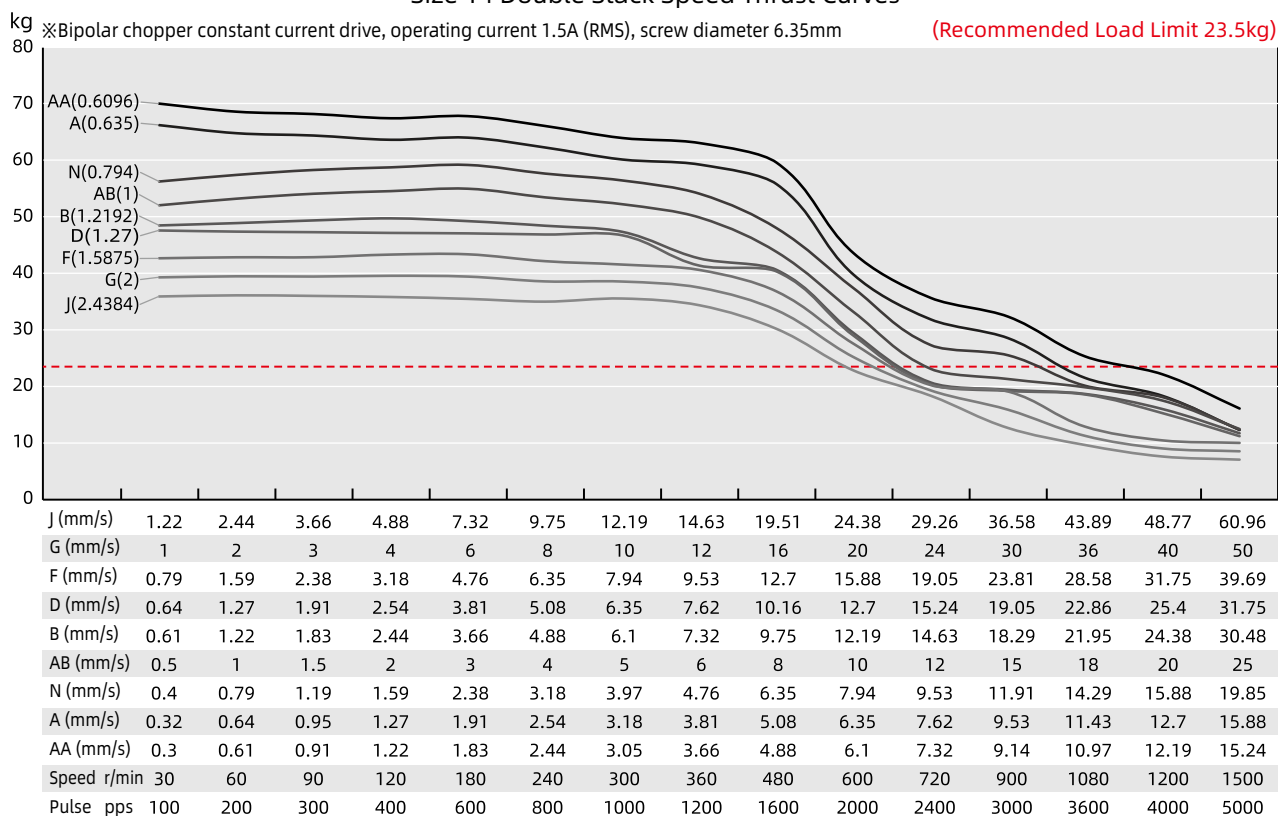

TEST CONDITION

Testing Voltage: 24Vdc, Driver Model: DS-OLS2-FPD bipolar, chopper driver at rated current (rms).
Motor's thrust will be changed with different voltage and driver. 50% thrust margin is recommended.

Size 14 Double Stack Speed Thrust Curves

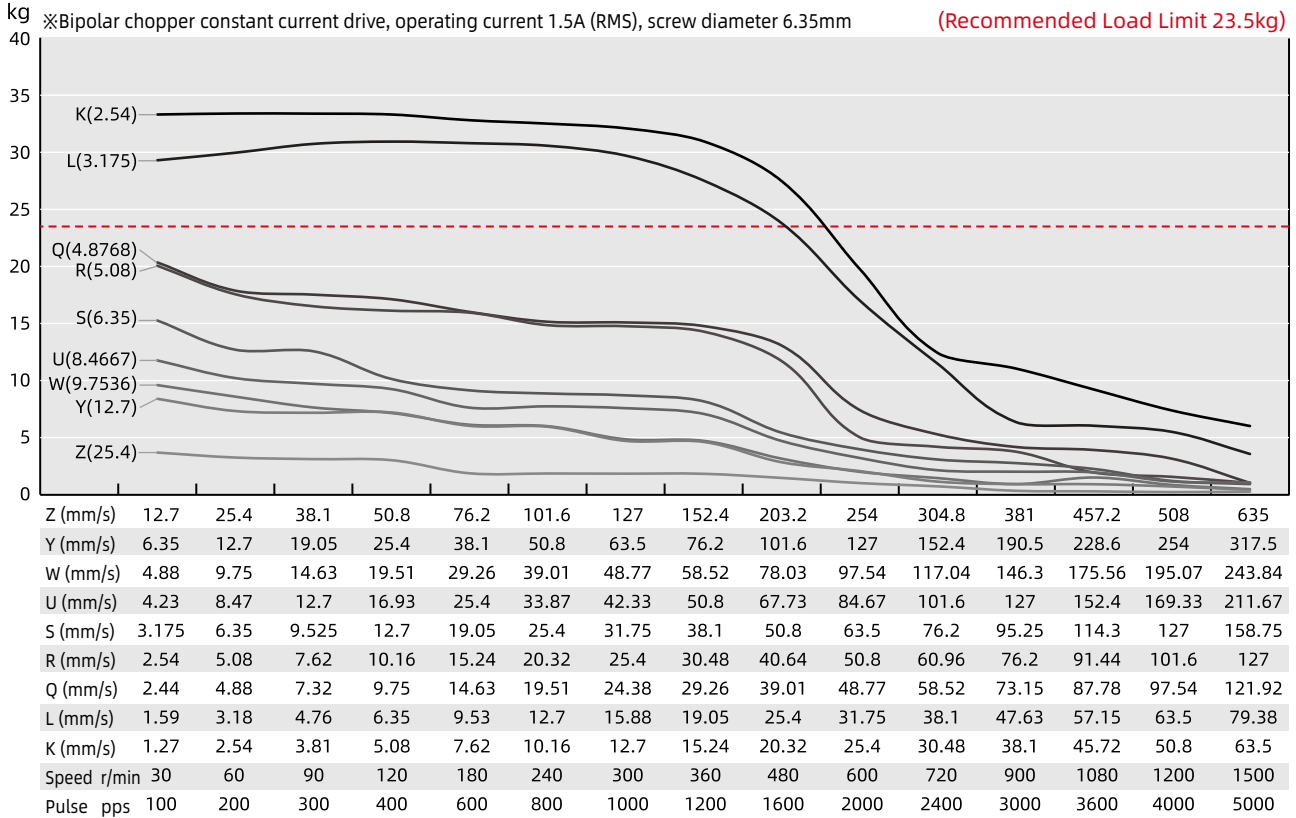

Size 14 Double Stack Speed Thrust Curves

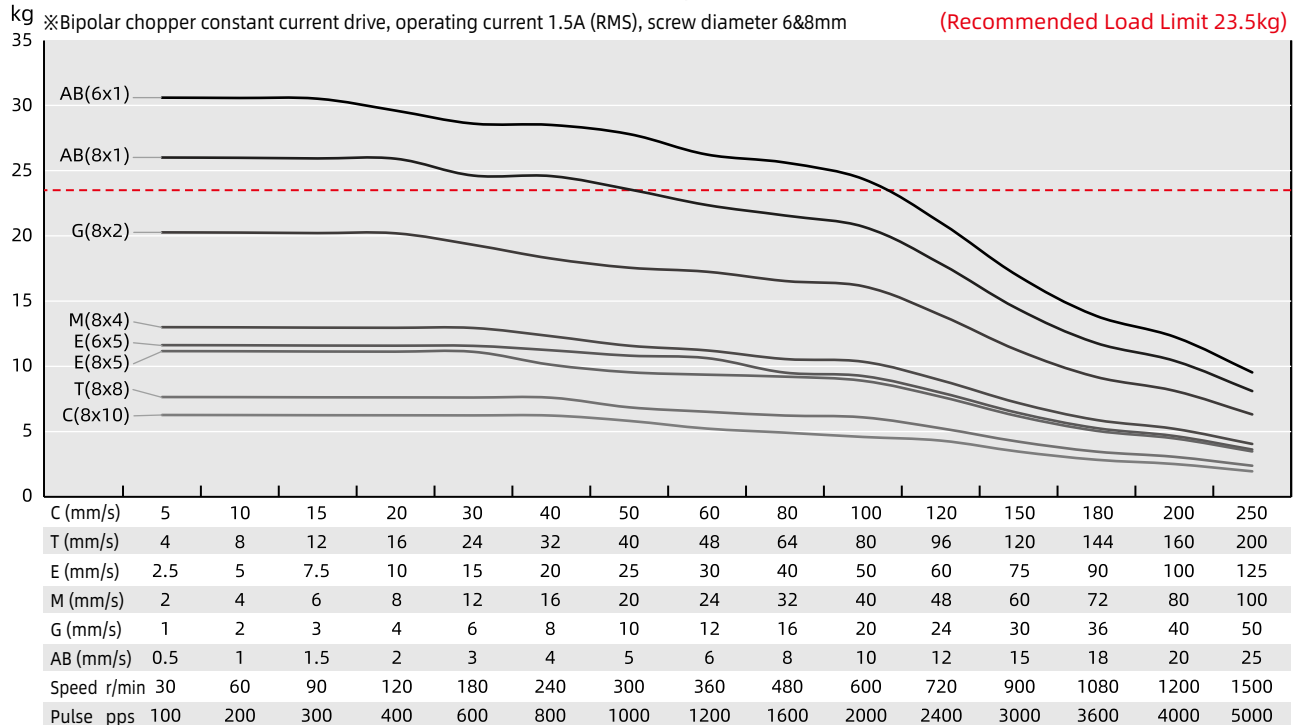

TEST CONDITION

Testing Voltage: 24Vdc, Driver Model: DS-OLS2-FPD bipolar, chopper driver at rated current (rms).
Motor's thrust will be changed with different voltage and driver. 50% thrust margin is recommended.

Size 42mm DLM / L·R DLM

Based on DINGS' platform products, high precision of lead screw linear actuator and self-developed simple linear module, DLM and LR-DLM 42mm series are compact and reliable linear solution structures.

DLM and LR-DLM 42mm series offer good precision, a high diversity of optional strokes, and lead-based customization. These linear modules can provide customers with integrated, customized solutions.



Motor Characteristics

Motor	Voltage (V)	Current (A _{RMS})	Resistance (Ω)	Inductance (mH)	Lead wire No.	Motor length (mm)
17E2105	7.2	0.5	14.4	19.8	4	34.1
17E2110	3.8	1.0	3.8	5.0	4	34.1
17E2115	2.85	1.5	1.9	2.2	4	34.1
17E2205	11.0	0.5	22	46	4	48.1
17E2212	4.5	1.2	3.8	8.0	4	48.1
17E2225	2.5	2.5	1.0	1.8	4	48.1

Available Lead Screw and Travel per Step

Screw Dia. (inch)	Screw Dia. (mm)	Lead (inch)	Lead (mm)	Lead Code	Travel Per Step @1.8° (mm)*
0.25	6.35	0.024	0.6096	AA	0.003048
0.25	6.35	0.0394	1	AB	0.005
0.25	6.35	0.048	1.2192	B	0.006096
0.25	6.35	0.05	1.27	D	0.00635
0.25	6.35	0.0625	1.5875	F*	0.0079
0.25	6.35	0.096	2.4384	J	0.0122
0.25	6.35	0.1	2.54	K	0.0127
0.25	6.35	0.125	3.175	L	0.0159
0.25	6.35	0.192	4.8768	Q	0.024
0.25	6.35	0.2	5.08	R	0.0254
0.25	6.35	0.25	6.35	S	0.0318
0.25	6.35	0.333	8.4667	U	0.0423
0.25	6.35	0.384	9.7536	W	0.0488
0.25	6.35	0.5	12.7	Y	0.0635
0.25	6.35	1	25.4	Z	0.127
0.31	8	0.1575	4	M	0.02
0.31	8	0.315	8	T	0.04
0.31	8	0.0787	2	G	0.01

* Lead code F is only available for LR-DLM 42mm

Size 42mm DLM / L·R DLM

Mechanical Specifications

Model	C100B(dyn)(N)	Co(stat)(N)	Mro(Nm)	Mpo(Nm)	Myo(Nm)
DLM / L·R DLM 42	1154	1732	10.75	6.45	6.45

Dimensional Drawings

42mm DLM

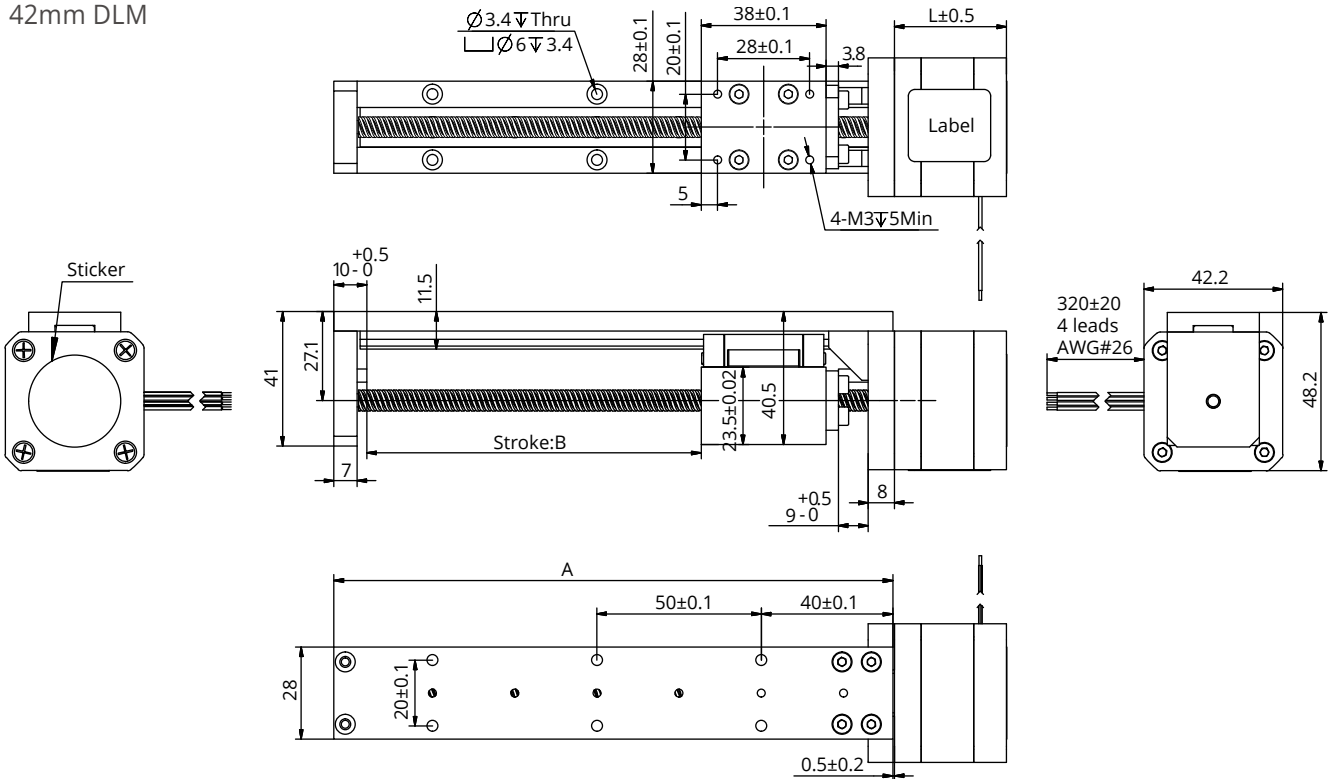

Available Stroke Selection

Size A (mm)	Stroke B (mm)
120	50
170	100
220	150
270	200
320	250
370	300
420	350
470	400
520	450
570	500

Size 42mm DLM / L·R DLM

● 42mm L·R DLM

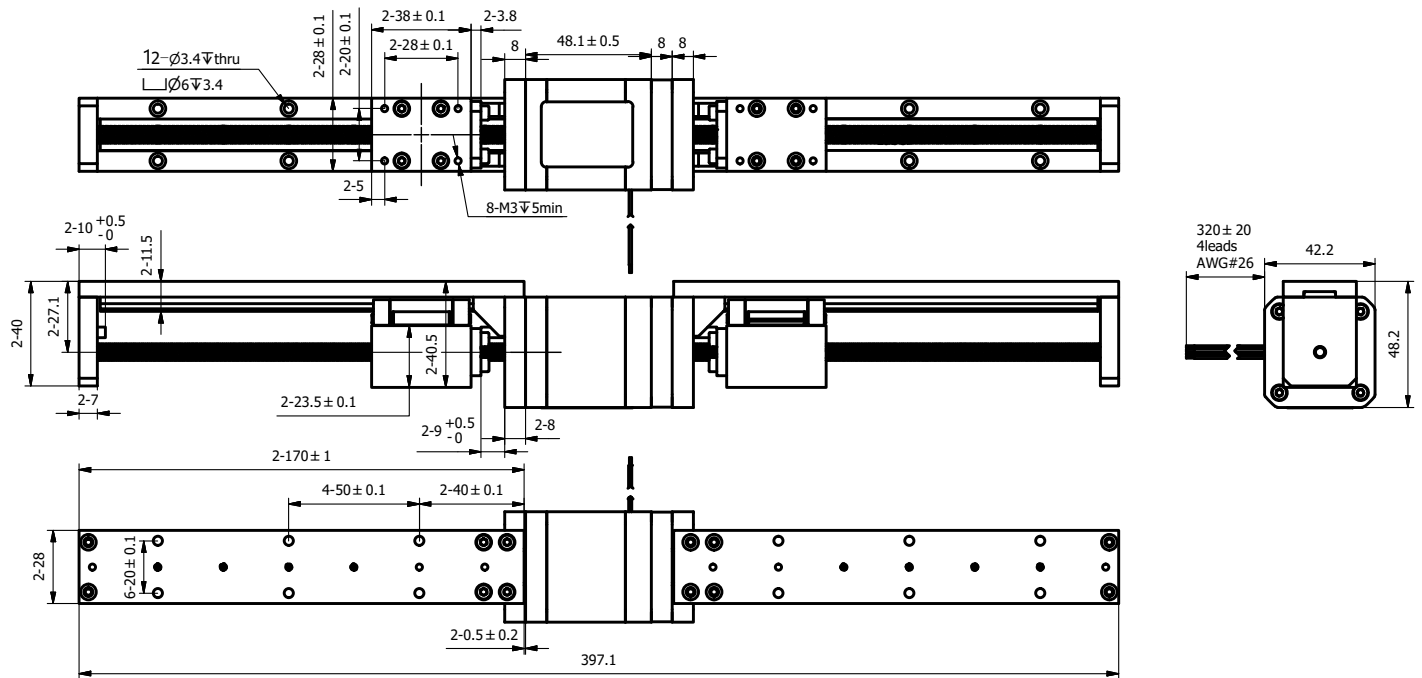

● Available Stroke Selection

Stroke (mm)	Total length (Dual motor-mm)
50	297
100	397
150	497
200	597
250	697
300	797
350	897
400	997

Size 42mm DLM / L·R DLM

Speed Thrust Curves

Size 17 Single Stack Speed Thrust Curves

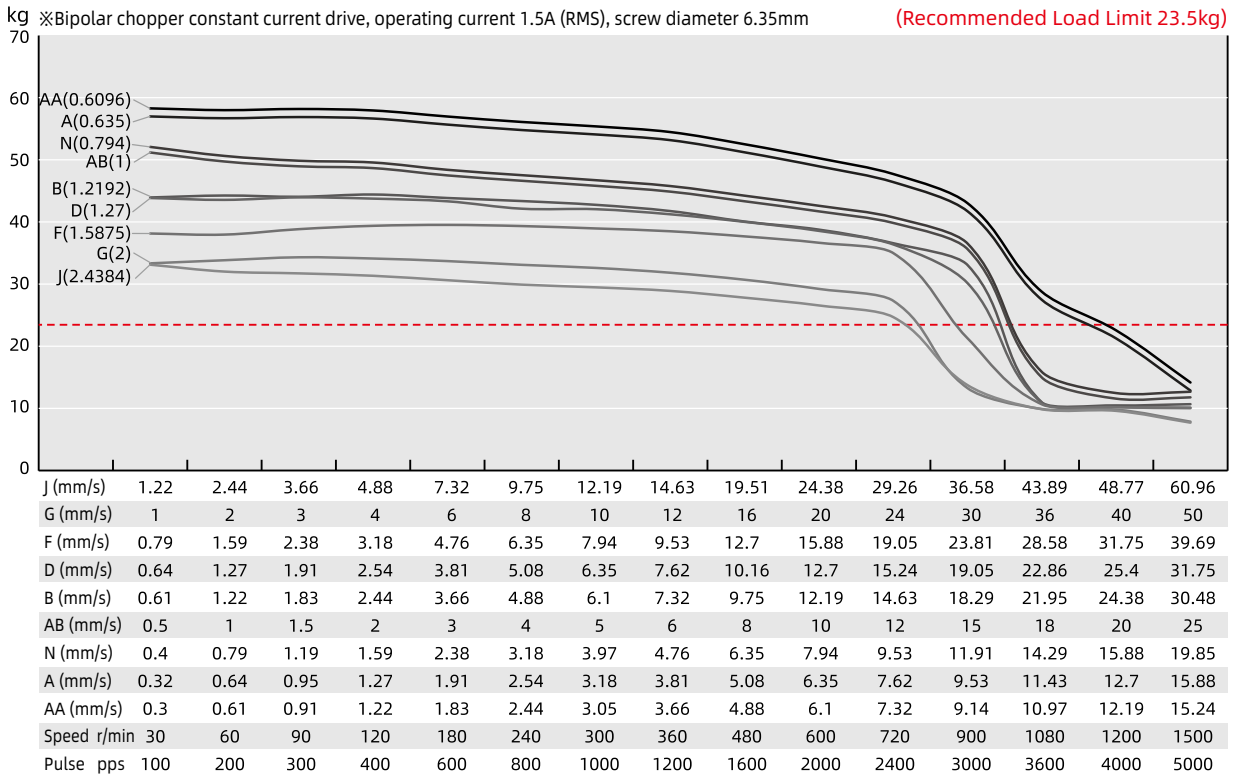

Size 17 Single Stack Speed Thrust Curves

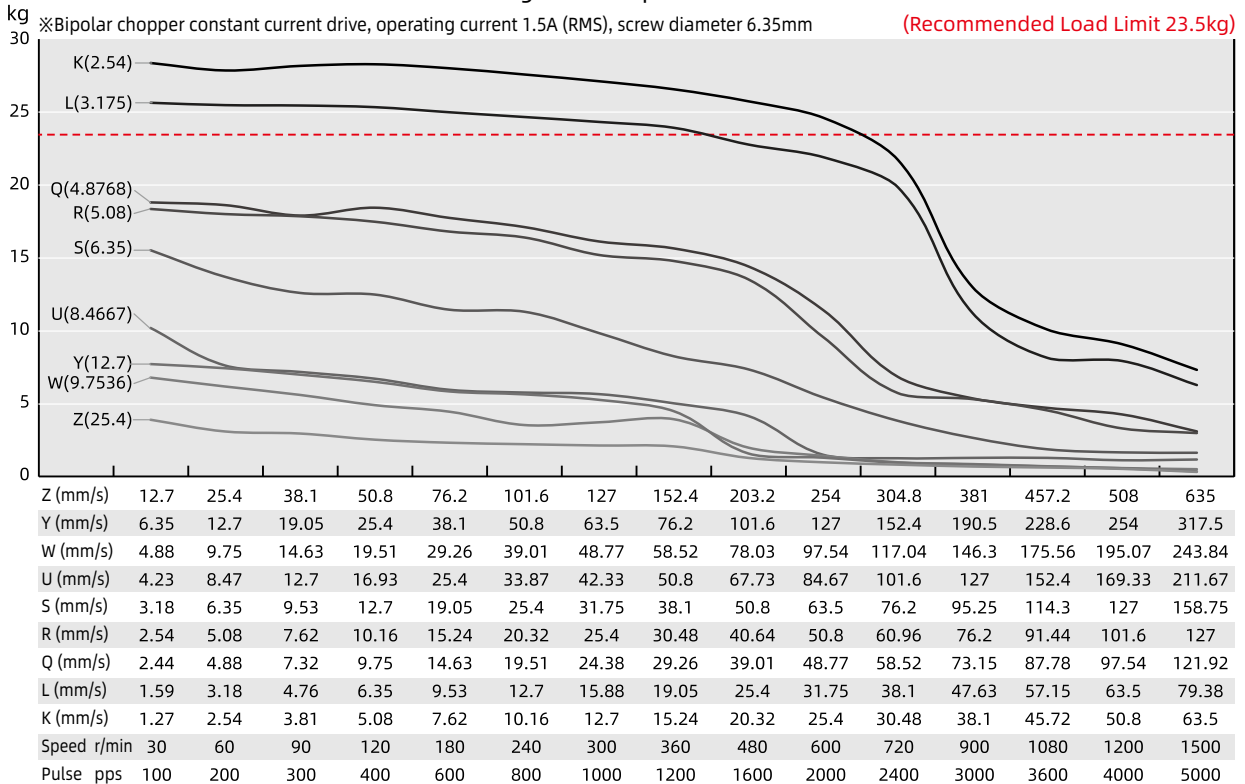

TEST CONDITION

Testing Voltage: 24Vdc, Driver Model: DS-OLS2-FPD bipolar, chopper driver at rated current (rms).
Motor's thrust will be changed with different voltage and driver. 50% thrust margin is recommended.

Size 42mm DLM / L·R DLM

Size 17 Single Stack Speed Thrust Curves

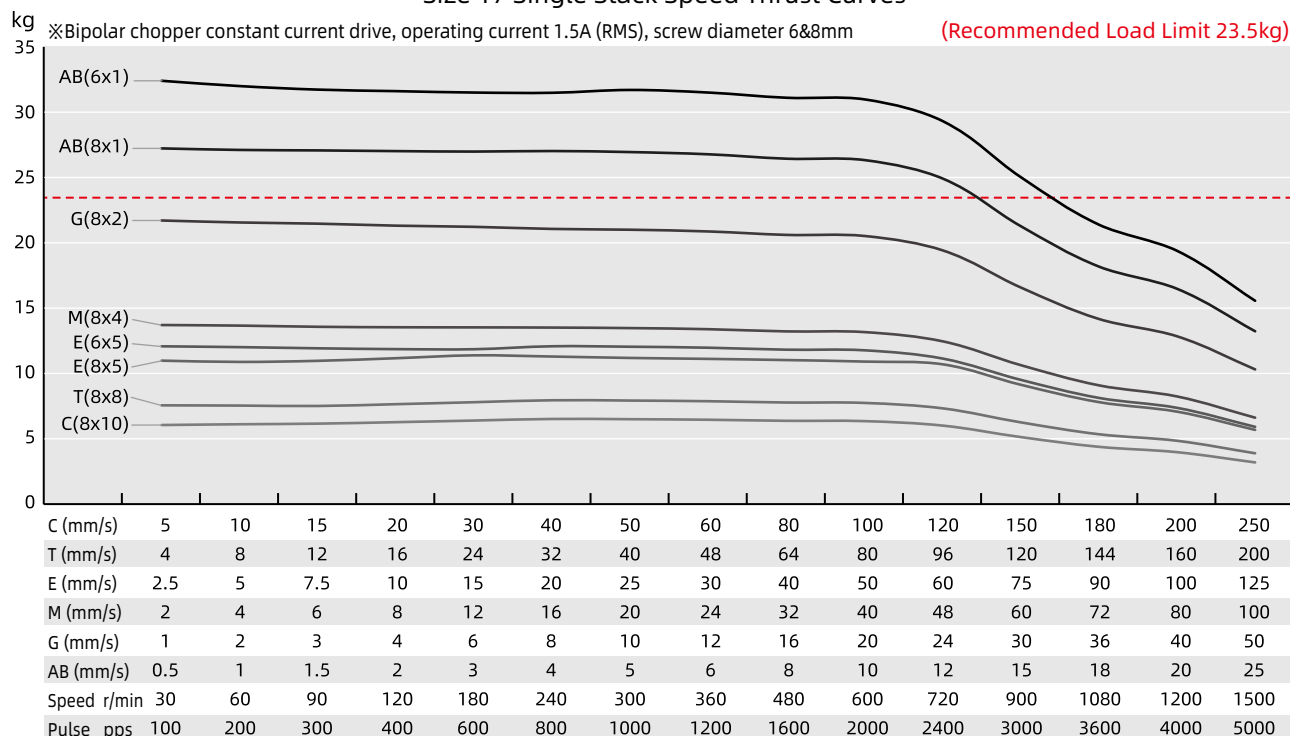

Size 17 Double Stack Speed Thrust Curves

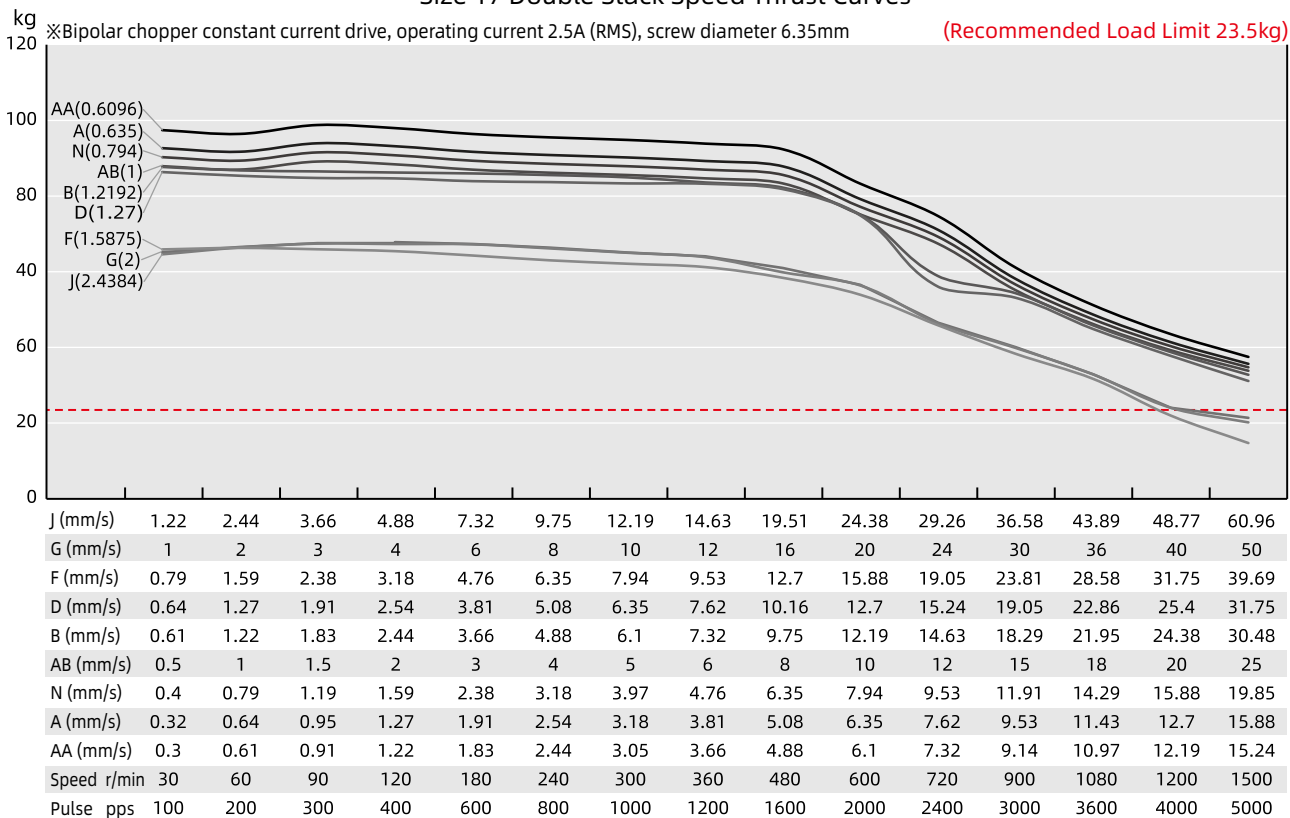

TEST CONDITION

Testing Voltage: 24Vdc, Driver Model: DS-OLS2-FPD bipolar, chopper driver at rated current (rms).
Motor's thrust will be changed with different voltage and driver. 50% thrust margin is recommended.

Size 42mm DLM / L·R DLM

Size 17 Double Stack Speed Thrust Curves

kg ※Bipolar chopper constant current drive, operating current 2.5A (RMS), screw diameter 6.35mm (Recommended Load Limit 23.5kg)

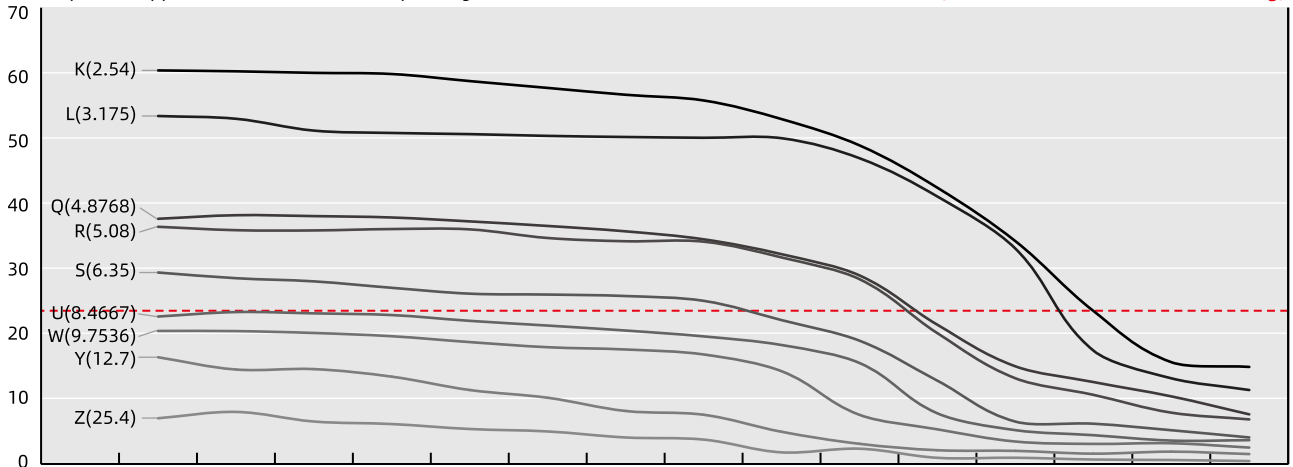

Z (mm/s)	12.7	25.4	38.1	50.8	76.2	101.6	127	152.4	203.2	254	304.8	381	457.2	508	635
Y (mm/s)	6.35	12.7	19.05	25.4	38.1	50.8	63.5	76.2	101.6	127	152.4	190.5	228.6	254	317.5
W (mm/s)	4.88	9.75	14.63	19.51	29.26	39.01	48.77	58.52	78.03	97.54	117.04	146.3	175.56	195.07	243.84
U (mm/s)	4.23	8.47	12.7	16.93	25.4	33.87	42.33	50.8	67.73	84.67	101.6	127	152.4	169.33	211.67
S (mm/s)	3.18	6.35	9.53	12.7	19.05	25.4	31.75	38.1	50.8	63.5	76.2	95.25	114.3	127	158.75
R (mm/s)	2.54	5.08	7.62	10.16	15.24	20.32	25.4	30.48	40.64	50.8	60.96	76.2	91.44	101.6	127
Q (mm/s)	2.44	4.88	7.32	9.75	14.63	19.51	24.38	29.26	39.01	48.77	58.52	73.15	87.78	97.54	121.92
L (mm/s)	1.59	3.18	4.76	6.35	9.53	12.7	15.88	19.05	25.4	31.75	38.1	47.63	57.15	63.5	79.38
K (mm/s)	1.27	2.54	3.81	5.08	7.62	10.16	12.7	15.24	20.32	25.4	30.48	38.1	45.72	50.8	63.5
Speed r/min	30	60	90	120	180	240	300	360	480	600	720	900	1080	1200	1500
Pulse pps	100	200	300	400	600	800	1000	1200	1600	2000	2400	3000	3600	4000	5000

Size 17 Double Stack Speed Thrust Curves

kg ※Bipolar chopper constant current drive, operating current 2.5A (RMS), screw diameter 6&8mm (Recommended Load Limit 23.5kg)

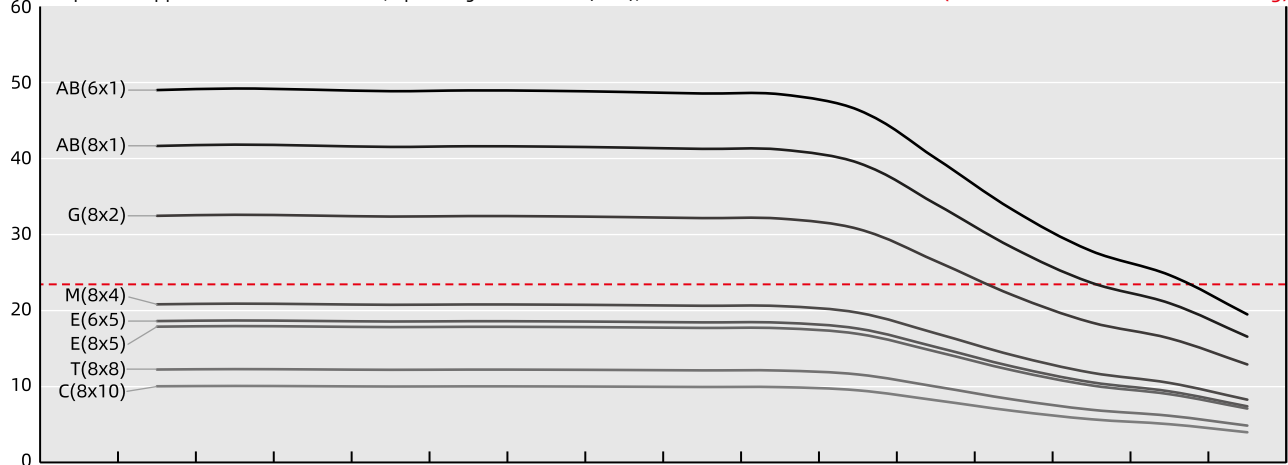

C (mm/s)	5	10	15	20	30	40	50	60	80	100	120	150	180	200	250
T (mm/s)	4	8	12	16	24	32	40	48	64	80	96	120	144	160	200
E (mm/s)	2.5	5	7.5	10	15	20	25	30	40	50	60	75	90	100	125
M (mm/s)	2	4	6	8	12	16	20	24	32	40	48	60	72	80	100
G (mm/s)	1	2	3	4	6	8	10	12	16	20	24	30	36	40	50
AB (mm/s)	0.5	1	1.5	2	3	4	5	6	8	10	12	15	18	20	25
Speed r/min	30	60	90	120	180	240	300	360	480	600	720	900	1080	1200	1500
Pulse pps	100	200	300	400	600	800	1000	1200	1600	2000	2400	3000	3600	4000	5000

TEST CONDITION

Testing Voltage: 24Vdc, Driver Model: DS-OLS2-FPD bipolar, chopper driver at rated current (rms).
Motor's thrust will be changed with different voltage and driver. 50% thrust margin is recommended.

Size 57mm DLM / L·R DLM

Based on DINGS' platform products, high precision of lead screw linear actuator and self-developed simple linear module, DLM and LR-DLM 57mm series are compact and reliable linear solution structures.

DLM and LR-DLM 57mm series offer good precision, a high diversity of optional strokes, and lead-based customization. These linear modules can provide customers with integrated, customized solutions.

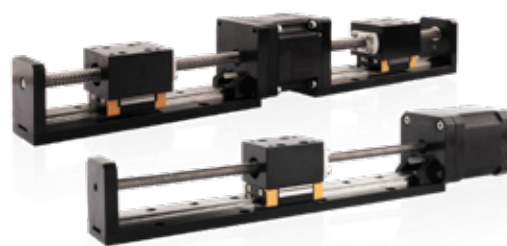

Motor Characteristics

Motor	Voltage (V)	Current (A _{RMS})	Resistance (Ω)	Inductance (mH)	Lead wire No.	Motor length (mm)
23E2110	6.4	1.0	6.4	16.4	4	45
23E2120	3.2	2.0	1.75	4.1	4	45
23E2130	2.4	3.0	0.8	1.7	4	45
23E2210	10.8	1.0	11.5	32	4	65
23E2225	4.2	2.5	2.0	5.2	4	65
23E2240	2.8	4.0	0.7	2.0	4	65

Available Lead Screw and Travel per Step

Screw Dia. (inch)	Screw Dia. (mm)	Lead (inch)	Lead (mm)	Lead Code	Travel Per Step @1.8° (mm)*
0.394	10	0.079	2	G	0.005
0.375	9.525	0.025	0.635	A	0.0016
0.375	9.525	0.05	1.27	D	0.0032
0.375	9.525	0.0625	1.5875	F	0.004
0.375	9.525	0.083	2.1167	H	0.0053
0.375	9.525	0.1	2.54	K*	0.0064
0.375	9.525	0.125	3.175	L	0.0079
0.375	9.525	0.167	4.233	P	0.0106
0.375	9.525	0.2	5.08	R	0.0127
0.375	9.525	0.25	6.35	S	0.0159
0.375	9.525	0.375	9.525	V	0.0238
0.375	9.525	0.384	9.7536	W	0.0244
0.375	9.525	0.4	10.16	X	0.0254
0.375	9.525	0.5	12.7	Y	0.0318
0.375	9.525	1	25.4	Z	0.0635

* Lead code K is only available for LR-DLM 57mm

Size 57mm DLM / L·R DLM

Mechanical Specifications

Model	C100B(dyn)(N)	Co(stat)(N)	Mro(Nm)	Mpo(Nm)	Myo(Nm)
DLM / L·R DLM 57	1905	2795	21.8	13.5	13.5

Dimensional Drawings

57mm DLM

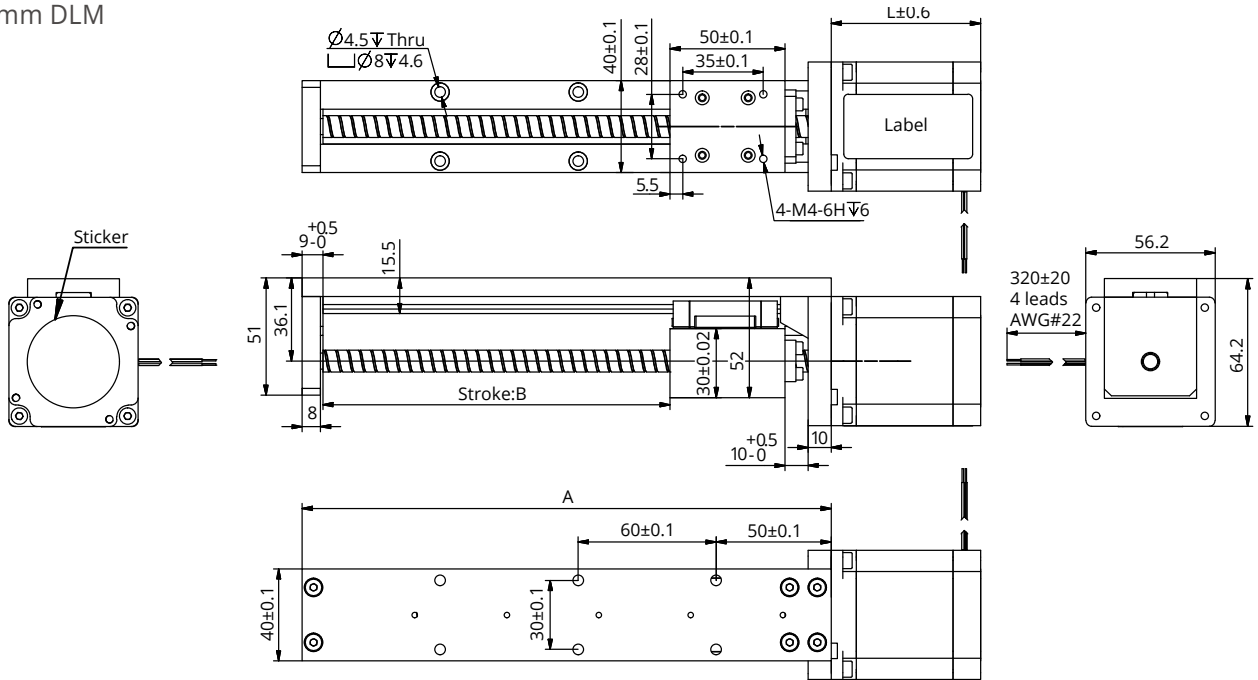

Available Stroke Selection

Size A (mm)	Stroke B (mm)
130	50
180	100
230	150
280	200
330	250
380	300
430	350
480	400
530	450
580	500
630	550
680	600

Size 57mm DLM / L·R DLM

● 57mm L·R DLM

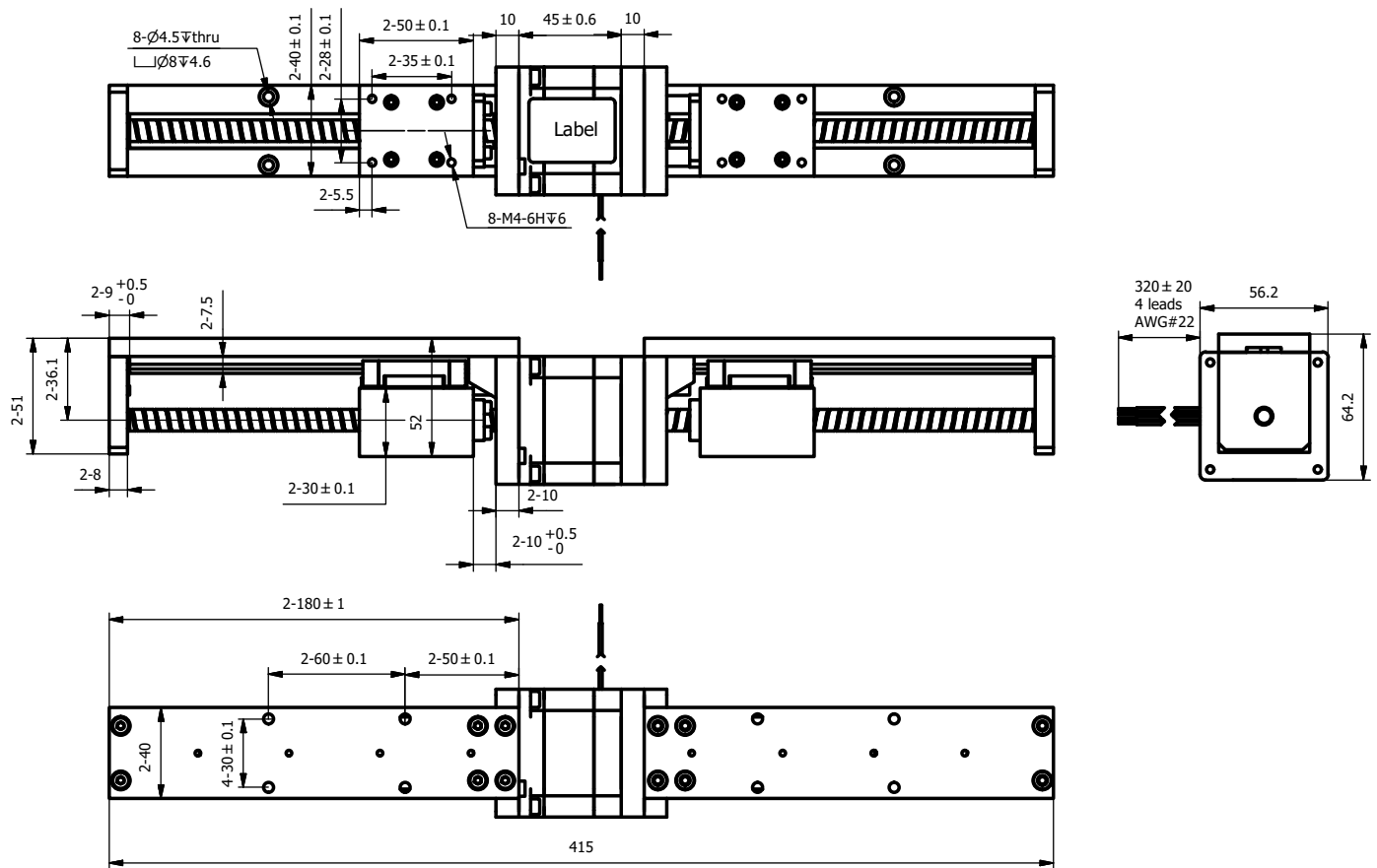

● Available Stroke Selection

Stroke (mm)	Total length (Dual motor-mm)
50	335
100	435
150	535
200	635
250	735
300	835
350	935
400	1035

Note : All drawings are 1st Angle Projection - ISO Compliant (3D models available)

Size 57mm DLM / L·R DLM

Speed Thrust Curves

Size 23 Single Stack Speed Thrust Curves

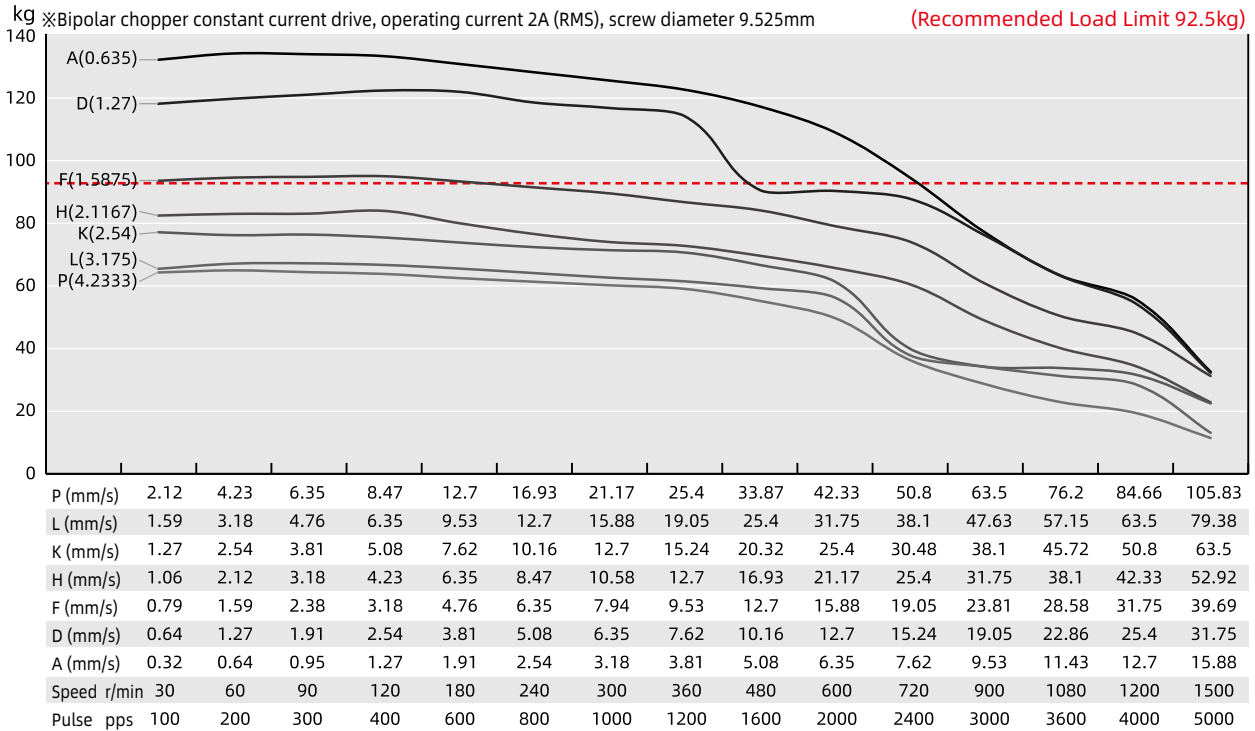

Size 23 Single Stack Speed Thrust Curves

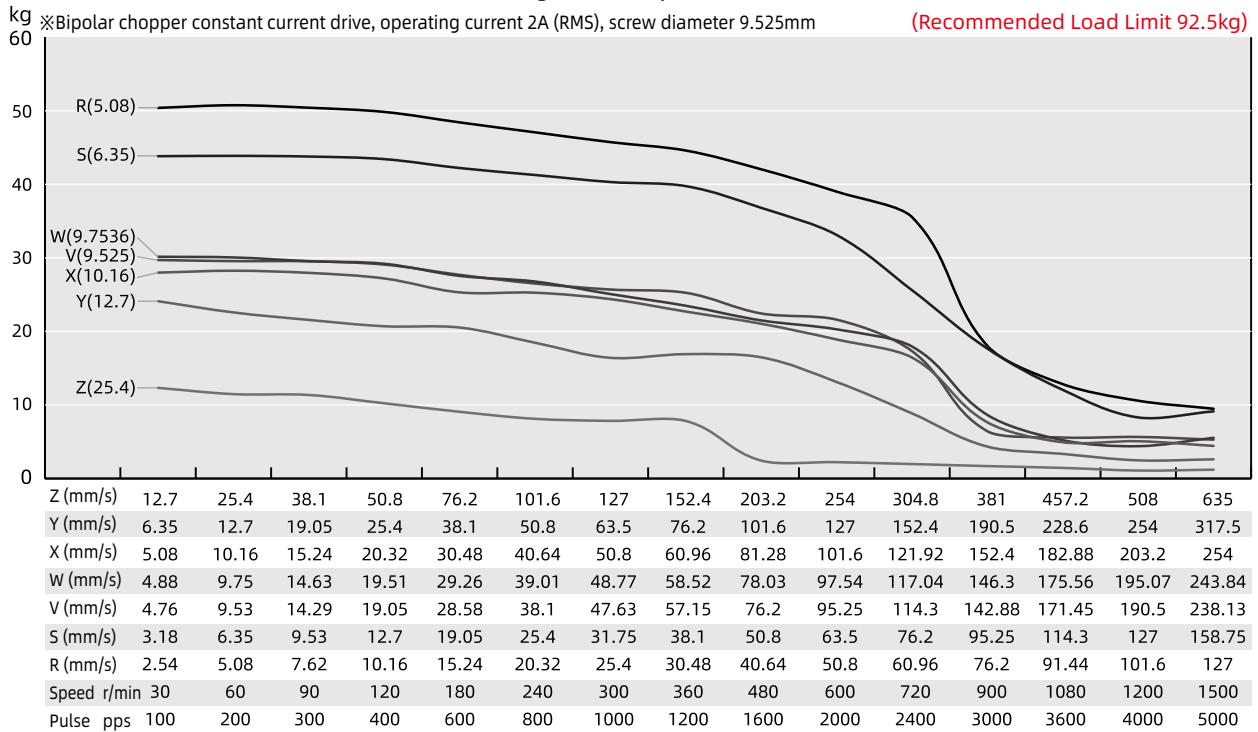

TEST CONDITION

Testing Voltage: 48Vdc, Driver Model: DS-OLS4-FPD bipolar, chopper driver at rated current (rms).

Motor's thrust will be changed with different voltage and driver. 50% thrust margin is recommended.

Size 57mm DLM / L·R DLM

Size 23 Single Stack Speed Thrust Curves

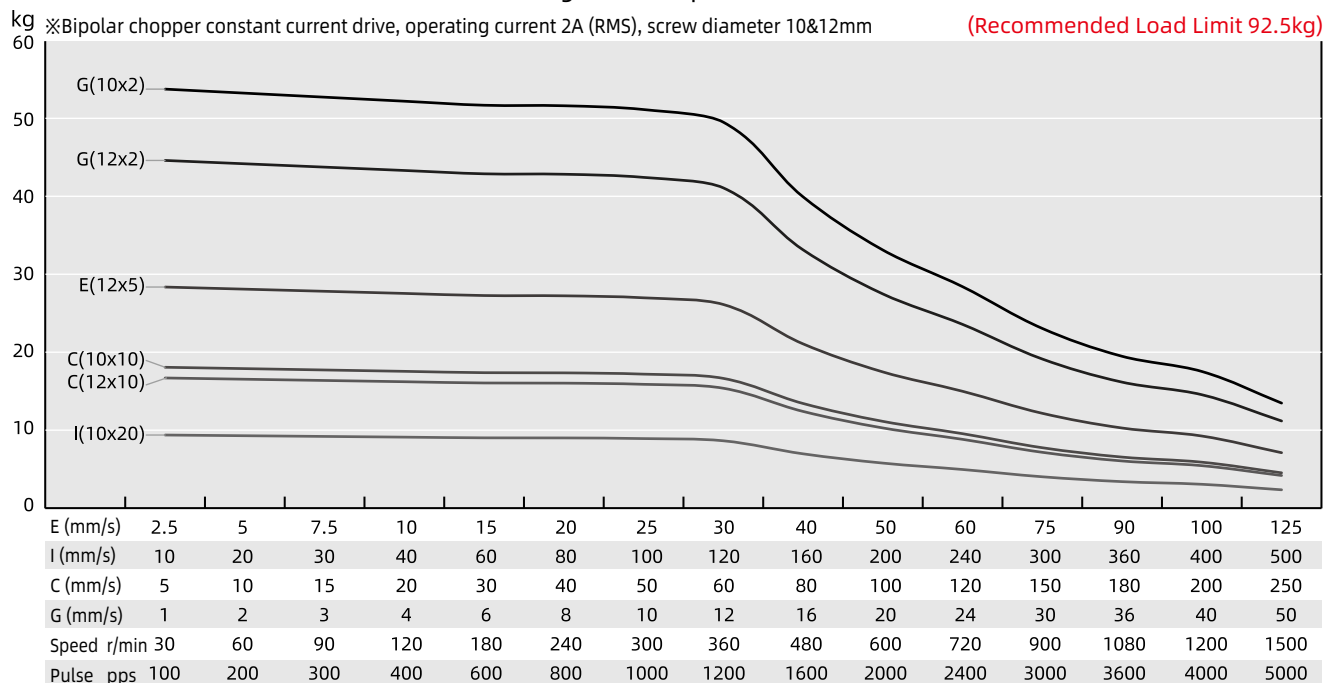

Size 23 Double Stack Speed Thrust Curves

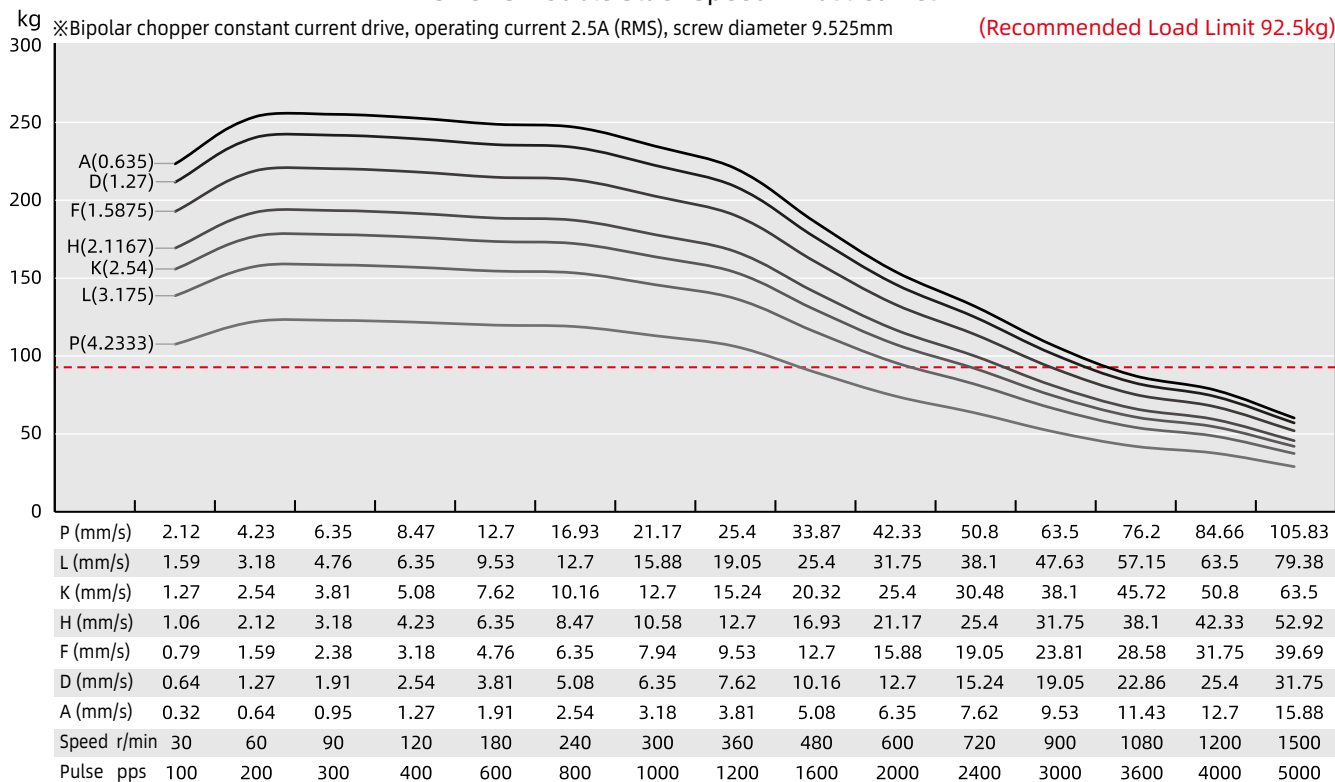

TEST CONDITION

Testing Voltage: 48Vdc, Driver Model: DS-OLS4-FPD bipolar, chopper driver at rated current (rms).
Motor's thrust will be changed with different voltage and driver. 50% thrust margin is recommended.

Size 57mm DLM / L·R DLM

Size 23 Double Stack Speed Thrust Curves

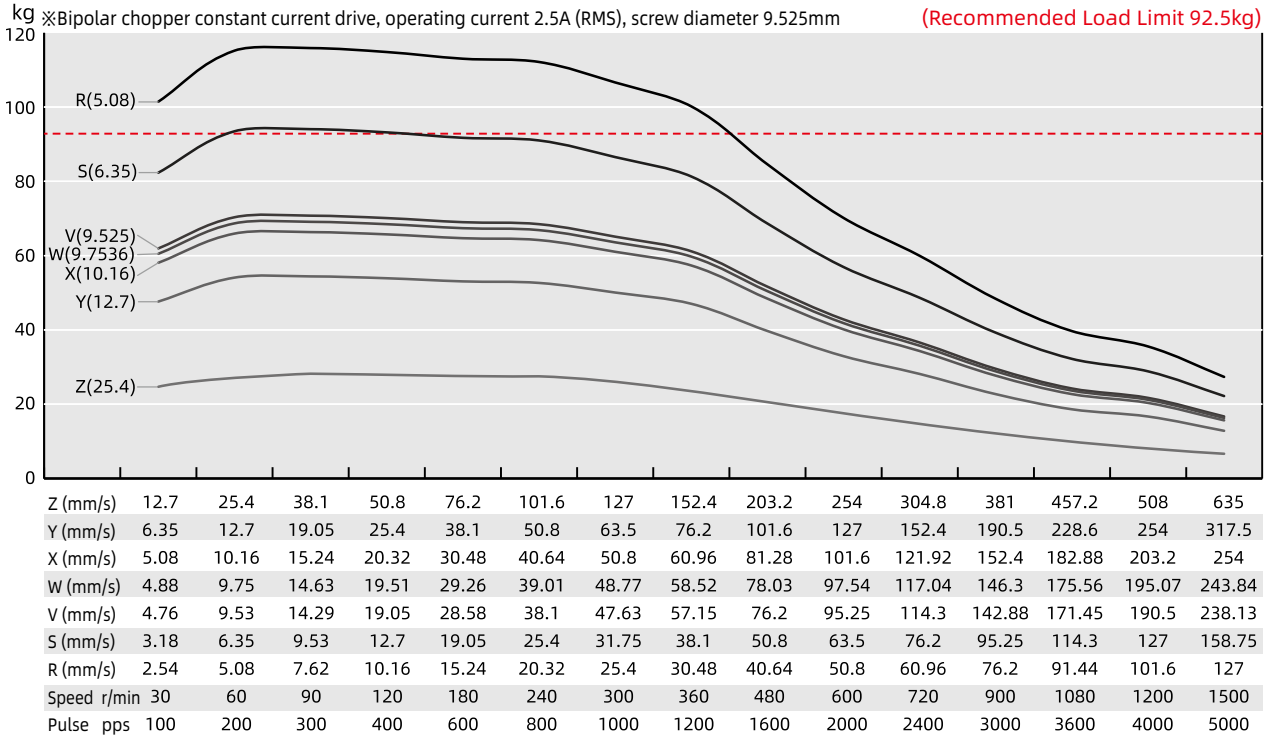

Size 23 Double Stack Speed Thrust Curves

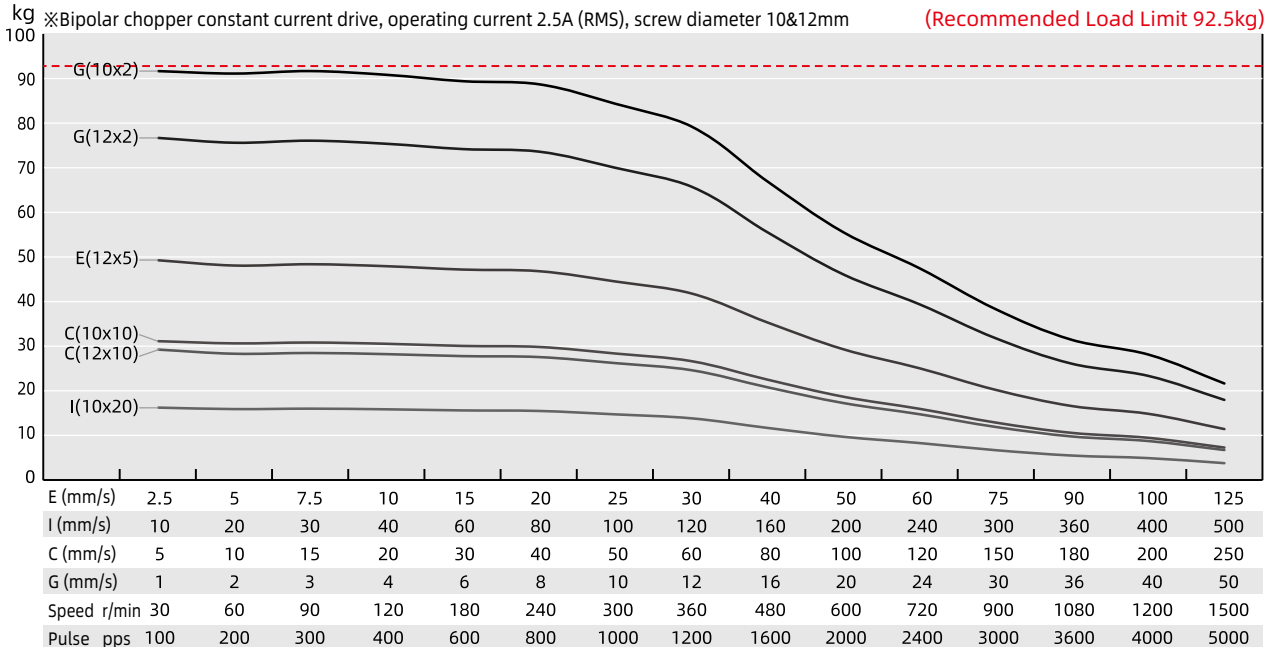

TEST CONDITION

Testing Voltage: 48Vdc, Driver Model: DS-OLS4-FPD bipolar, chopper driver at rated current (rms).

Motor's thrust will be changed with different voltage and driver. 50% thrust margin is recommended.

Part Number Construction

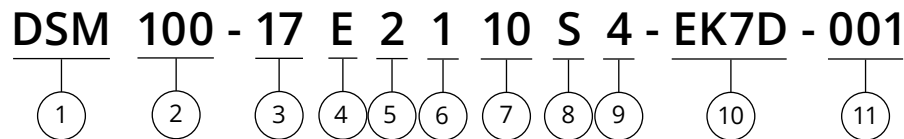

- | | | | | | | | | | | | | | |
|--|-----------------|----|----|----|----|----|-------------------|---|---|----|----|----|--|
| <p>① Product Name
DSM Series Module</p> <p>② Stroke (mm)
100 = 100mm</p> <p>③ Motor Size</p> <table border="1" style="margin-left: 20px;"> <tr> <td>Motor Size (mm)</td> <td>14</td> <td>20</td> <td>28</td> <td>35</td> <td>42</td> </tr> <tr> <td>Motor Size (NEMA)</td> <td>6</td> <td>8</td> <td>11</td> <td>14</td> <td>17</td> </tr> </table> <p>④ Motor Type
E = External type
N = Non-Captive type</p> <p>⑤ Motor Step Angle
2 = 2 Phase with 1.8°
4 = 2 Phase with 0.9°</p> <p>⑥ Motor Length
1 = Single stack
2 = Double stack</p> | Motor Size (mm) | 14 | 20 | 28 | 35 | 42 | Motor Size (NEMA) | 6 | 8 | 11 | 14 | 17 | <p>⑦ Rated Current / Phase
XX = X.X (A) / Phase</p> <p>⑧ Lead Screw Code
Please refer to lead screw code selection table</p> <p>⑨ Number of Lead Wires
4 = 4 Flying leads
6 = 6 Flying leads</p> <p>⑩ Option
EKX = Encoder [X = Encoder Resolution]
P = Manual Knob
B = Brake
X = Rear Shaft
R = Encoder Ready
C = Customize
N = No processing at the rear end</p> <p>⑪ Customer Sequence Number</p> |
| Motor Size (mm) | 14 | 20 | 28 | 35 | 42 | | | | | | | | |
| Motor Size (NEMA) | 6 | 8 | 11 | 14 | 17 | | | | | | | | |

Example

Part Number	DSM100-17E2110S4-EK7D-001
Description	<p>DSM Linear Module</p> <p>100mm Stroke</p> <p>NEMA 17 External Linear Actuator</p> <p>2 Phase / 1.8° Stepper</p> <p>Single Stack</p> <p>1.0A / Phase</p> <p>S Lead (0.25" or 6.35mm)</p> <p>4 Flying Wires</p> <p>EK7D Encoder with differential output 1,000 lines</p> <p>Serial Number 001</p>

Size 14mm DSM

Based on DINGS' platform products, high precision of lead screw linear actuator and self-developed simple linear module, DLM 14mm series is compact and reliable structure of linear solution.

DSM 14mm Series is good precision, high diversity of optional stroke and lead based customization linear module which can provide customers with integrated customization solutions.

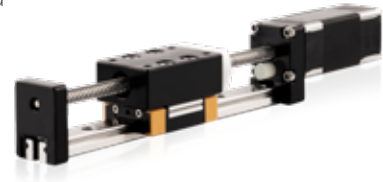

Motor Characteristics

Motor	Voltage (V)	Current (A (RMS))	Resistance (Ω)	Inductance (mH)	Weight (g)	Lead wire No.	Motor length (mm)
6E2103	6.6	0.3	22	4.5	60	4	32

Available Lead Screw and Travel per Step

Screw Dia. (inch)	Screw Dia. (mm)	Lead (inch)	Lead (mm)	Lead Code	Travel Per Step @1.8° (mm)*
0.138	3.5	0.0118	0.3	AF	0.0015
0.138	3.5	0.024	0.6096	AA	0.003048
0.138	3.5	0.048	1.2192	B	0.006096
0.138	3.5	0.0787	2	G	0.01
0.138	3.5	0.1575	4	M	0.02
0.138	3.5	0.315	8	T	0.04

Dimensional Drawings

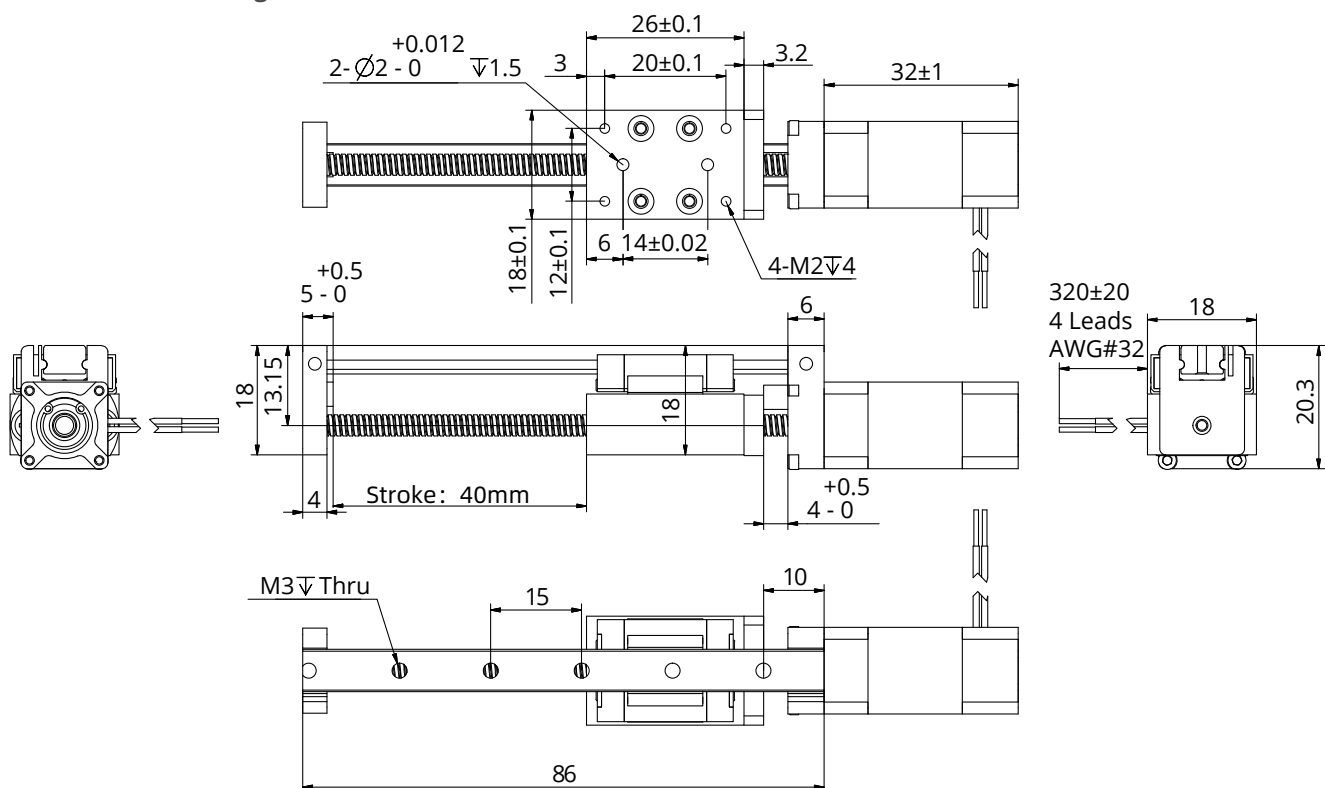

Size 20mm DSM

Based on DINGS' platform products, high precision of lead screw linear actuator and self-developed simple linear module, DSM 20mm series is compact and reliable structure of linear solution.

DSM 20mm Series is good precision, high diversity of optional stroke and lead based customization linear module which can provide customers with integrated customization solutions.

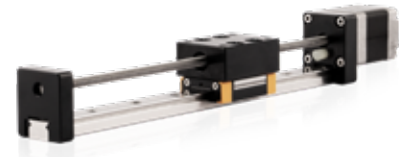

Motor Characteristics

Motor	Voltage (V)	Current (A _{RMS})	Resistance (Ω)	Inductance (mH)	Lead wire No.	Motor length (mm)
8E2105	2.5	0.5	5.1	1.5	4	27.2
8E2205	4.4	0.5	8.8	2.7	4	38.1

Available Lead Screw and Travel per Step

Screw Dia. (inch)	Screw Dia. (mm)	Lead (inch)	Lead (mm)	Lead Code	Travel Per Step @1.8° (mm)*
0.138	3.5	0.0118	0.3	AF	0.0015
0.138	3.5	0.024	0.6096	AA	0.003048
0.138	3.5	0.0394	1	AB	0.005
0.138	3.5	0.048	1.2192	B	0.006096
0.138	3.5	0.0787	2	G	0.01
0.138	3.5	0.1575	4	M	0.02
0.138	3.5	0.315	8	T	0.04

Dimensional Drawings

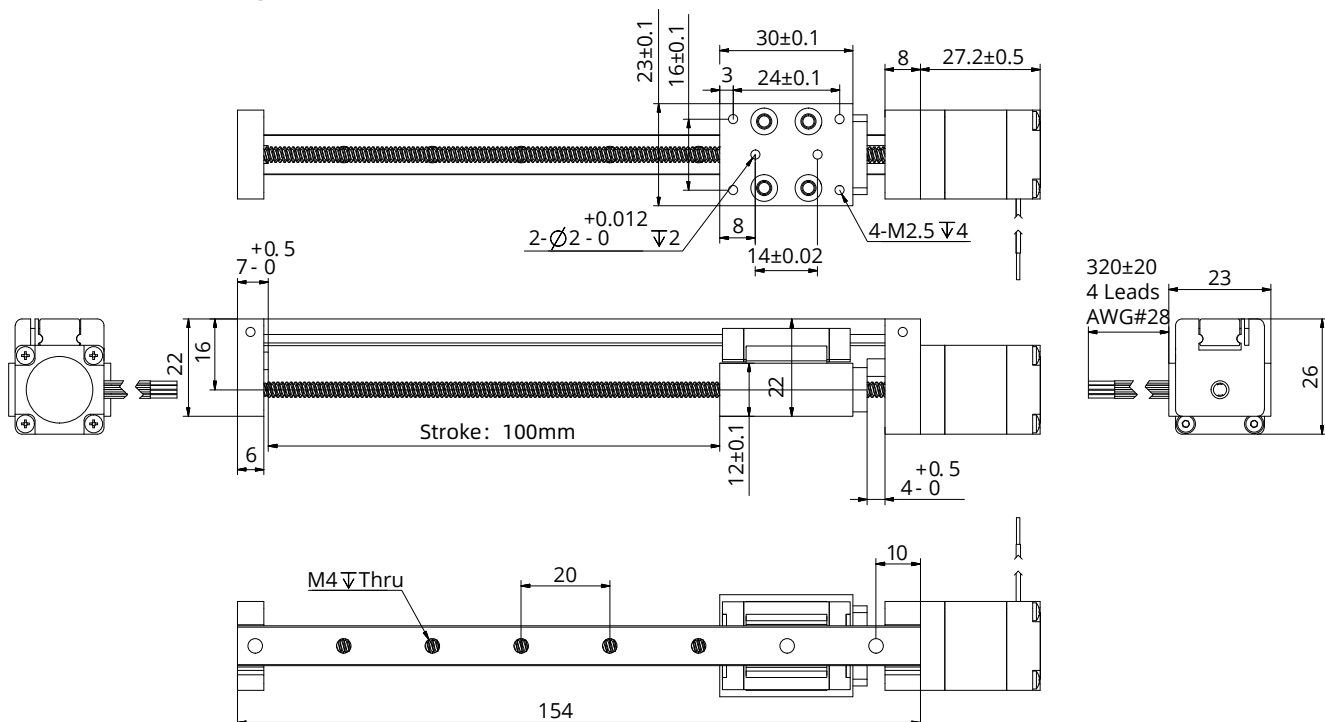

Note: Any travel can be customized within the maximum travel range

Size 28mm DSM

Based on DINGS' platform products, high precision of lead screw linear actuator and self-developed simple linear module, DSM 28mm series is compact and reliable structure of linear solution.

DSM 28mm Series is good precision, high diversity of optional stroke and lead based customization linear module which can provide customers with integrated customization solutions.

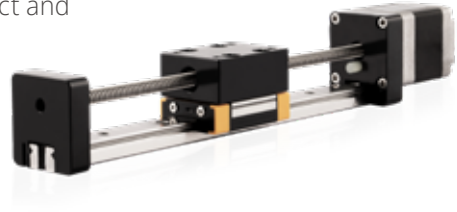

Motor Characteristics

Motor	Voltage (V)	Current (A _{RMS})	Resistance (Ω)	Inductance (mH)	Lead wire No.	Motor length (mm)
11E2105	4.55	0.5	9.1	6.0	4	33.35
11E2110	2.1	1.0	2.1	1.5	4	33.35
11E2209	3.9	0.95	4.1	4.0	4	45
11E2216	2.4	1.6	1.5	1.3	4	45

Available Lead Screw and Travel per Step

Screw Dia. (inch)	Screw Dia. (mm)	Lead (inch)	Lead (mm)	Lead Code	Travel Per Step @1.8° (mm)*
0.188	4.77	0.0128	0.3175	AL	0.0016
0.188	4.77	0.025	0.635	A	0.003175
0.188	4.77	0.05	1.27	D	0.00635
0.188	4.77	0.1	2.54	K	0.0127
0.188	4.77	0.2	5.08	R	0.0254
0.188	4.77	0.4	10.16	X	0.0508

Dimensional Drawings

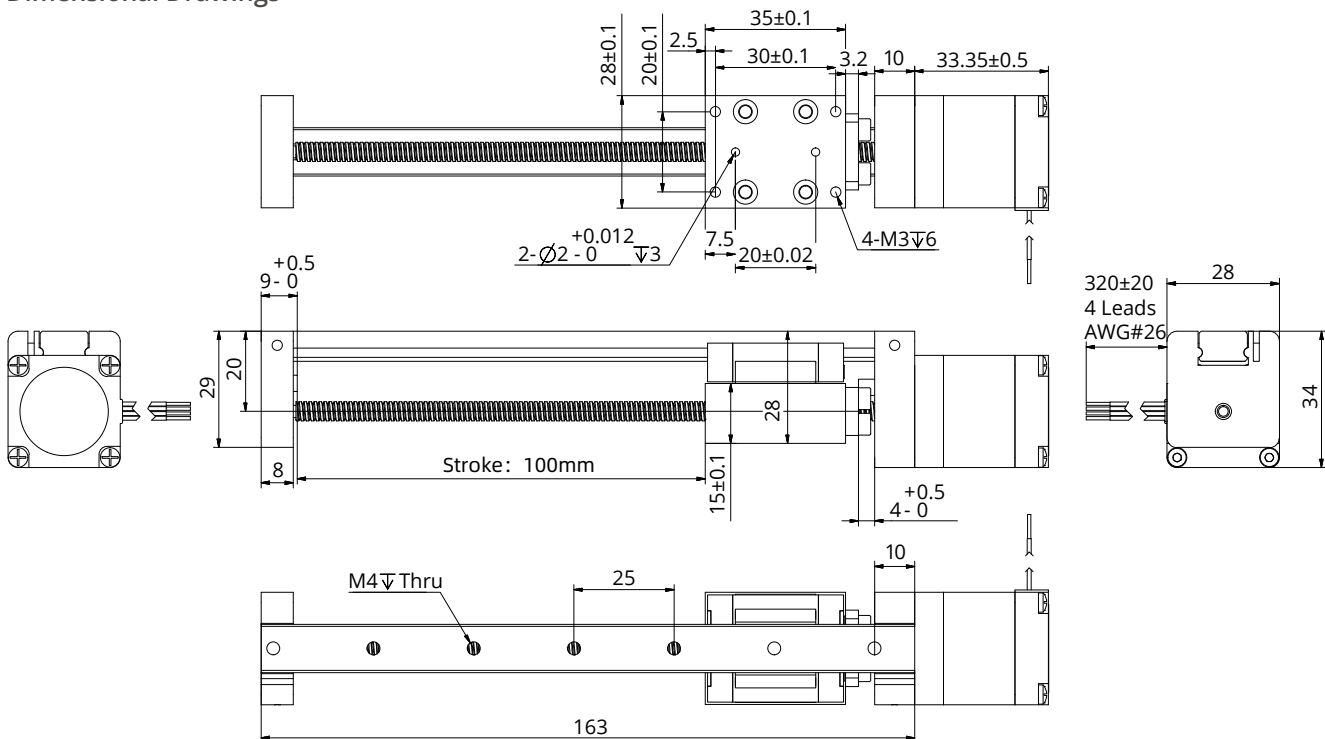

Note: Any travel can be customized within the maximum travel range

Size 35mm DSM

Based on DINGS' platform products, high precision of lead screw linear actuator and self-developed simple linear module, DSM 35mm series is compact and reliable structure of linear solution.

DSM 35mm Series is good precision, high diversity of optional stroke and lead based customization linear module which can provide customers with integrated customization solutions.

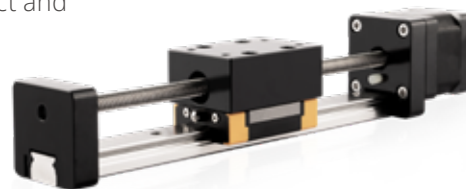

Motor Characteristics

Motor	Voltage (V)	Current (A _{RMS})	Resistance (Ω)	Inductance (mH)	Lead wire No.	Motor length (mm)
14E2105	6.6	0.5	13.2	14	4	33.6
14E2110	3.5	1.0	3.5	3.6	4	33.6
14E2115	2.7	1.5	1.8	1.9	4	33.6
14E2205	12.0	0.5	24.0	29	4	45.6
14E2210	6.0	1.0	6.0	7.2	4	45.6
14E2215	4.0	1.5	2.7	3.2	4	45.6

Available Lead Screw and Travel per Step

Screw Dia. (inch)	Screw Dia. (mm)	Lead (inch)	Lead (mm)	Lead Code	Travel Per Step @1.8° (mm)*
0.25	6.35	0.024	0.6096	AA	0.003048
0.25	6.35	0.0394	1	AB	0.005
0.25	6.35	0.048	1.2192	B	0.006096
0.25	6.35	0.05	1.27	D	0.00635
0.25	6.35	0.0625	1.5875	F	0.0079
0.25	6.35	0.096	2.4384	J	0.0122
0.25	6.35	0.1	2.54	K	0.0127
0.25	6.35	0.125	3.175	L	0.0159
0.25	6.35	0.192	4.8768	Q	0.024
0.25	6.35	0.2	5.08	R	0.0254
0.25	6.35	0.25	6.35	S	0.0318
0.25	6.35	0.333	8.4667	U	0.0423
0.25	6.35	0.384	9.7536	W	0.0488
0.25	6.35	0.5	12.7	Y	0.0635
0.25	6.35	1	25.4	Z	0.127
0.31	8	0.1575	4	M	0.02
0.31	8	0.315	8	T	0.04
0.31	8	0.0787	2	G	0.01

Note: Any travel can be customized within the maximum travel range

Size 35mm DSM

Dimensional Drawings

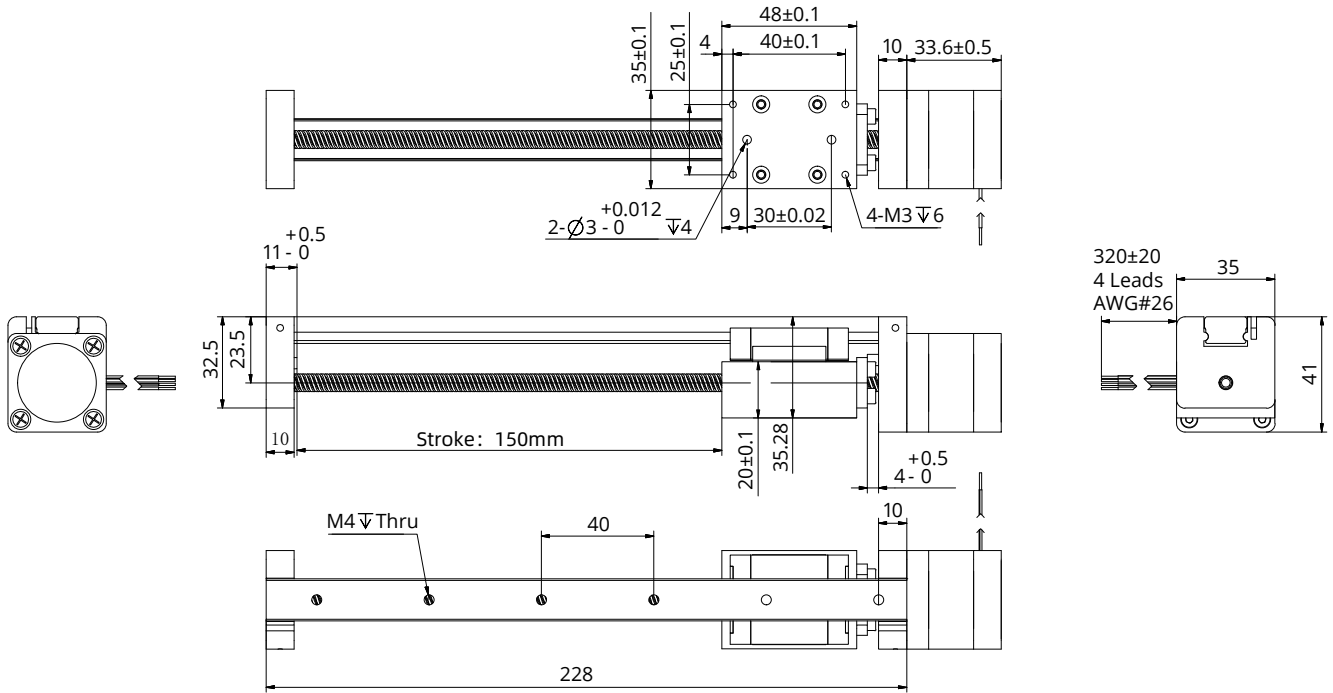

Size 42mm DSM

Based on DINGS' platform products, high precision of lead screw linear actuator and self-developed simple linear module, DSM 42mm series is compact and reliable structure of linear solution.

DSM 42mm Series is good precision, high diversity of optional stroke and lead based customization linear module which can provide customers with integrated customization solutions.

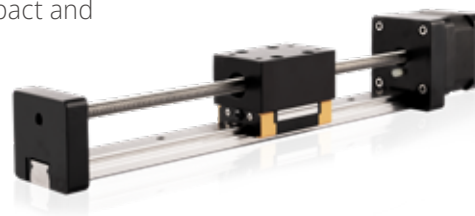

Motor Characteristics

Motor	Voltage (V)	Current (A _{RMS})	Resistance (Ω)	Inductance (mH)	Lead wire No.	Motor length (mm)
17E2105	7.2	0.5	14.4	19.8	4	34.1
17E2110	3.8	1.0	3.8	5.0	4	34.1
17E2115	2.85	1.5	1.9	2.2	4	34.1
17E2205	11.0	0.5	22	46	4	48.1
17E2212	4.5	1.2	3.8	8.0	4	48.1
17E2225	2.5	2.5	1.0	1.8	4	48.1

Available Lead Screw and Travel per Step

Screw Dia. (inch)	Screw Dia. (mm)	Lead (inch)	Lead (mm)	Lead Code	Travel Per Step @1.8° (mm)*
0.25	6.35	0.024	0.6096	AA	0.003048
0.25	6.35	0.0394	1	AB	0.005
0.25	6.35	0.048	1.2192	B	0.006096
0.25	6.35	0.05	1.27	D	0.00635
0.25	6.35	0.0625	1.5875	F	0.0079
0.25	6.35	0.096	2.4384	J	0.0122
0.25	6.35	0.1	2.54	K	0.0127
0.25	6.35	0.125	3.175	L	0.0159
0.25	6.35	0.192	4.8768	Q	0.024
0.25	6.35	0.2	5.08	R	0.0254
0.25	6.35	0.25	6.35	S	0.0318
0.25	6.35	0.333	8.4667	U	0.0423
0.25	6.35	0.384	9.7536	W	0.0488
0.25	6.35	0.5	12.7	Y	0.0635
0.25	6.35	1	25.4	Z	0.127
0.31	8	0.1575	4	M	0.02
0.31	8	0.315	8	T	0.04
0.31	8	0.0787	2	G	0.01

Note: Any travel can be customized within the maximum travel range

Size 42mm DSM

Dimensional Drawings

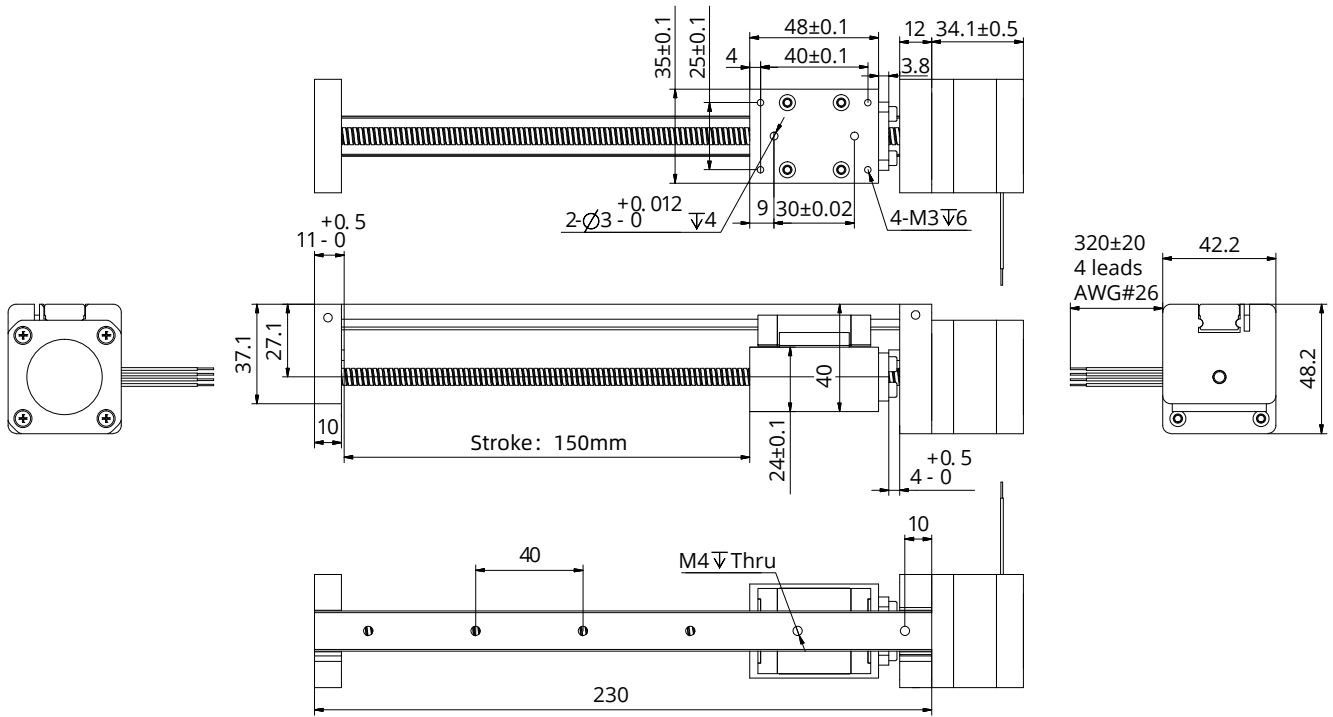

Part Number Construction

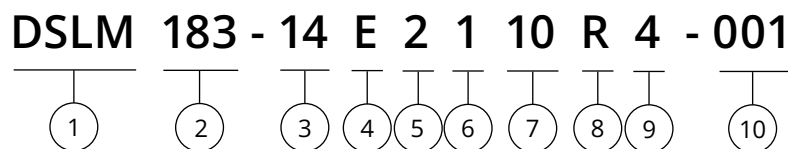

- | | | | | | | | | | |
|---|-----------------|----|----|----|-------------------|----|----|----|---|
| <p>① Product Name
DSL Series Module</p> <p>② Stroke (mm)
183 = 183mm</p> <p>③ Motor Size</p> <table border="1" style="margin-left: 20px;"> <tr> <td>Motor Size (mm)</td> <td>35</td> <td>42</td> <td>57</td> </tr> <tr> <td>Motor Size (NEMA)</td> <td>14</td> <td>17</td> <td>23</td> </tr> </table> <p>④ Motor Type
E = External type</p> <p>⑤ Motor Step Angle
2 = 2 Phase with 1.8°</p> | Motor Size (mm) | 35 | 42 | 57 | Motor Size (NEMA) | 14 | 17 | 23 | <p>⑥ Motor Length
1 = Single stack
2 = Double stack</p> <p>⑦ Rated Current / Phase
XX = X.X (A) / Phase</p> <p>⑧ Lead Screw Code
Please refer to lead screw code selection table</p> <p>⑨ Number of Lead Wires
4 = 4 Flying leads</p> <p>⑩ Customer Sequence Number</p> |
| Motor Size (mm) | 35 | 42 | 57 | | | | | | |
| Motor Size (NEMA) | 14 | 17 | 23 | | | | | | |

Example

Part Number	DSL183-14E2110R4-001
Description	DSLM Linear Module 183mm Stroke NEMA 14 External Linear Actuator 2 Phase / 1.8° Stepper Single Stack 1.0A / Phase R Lead (0.2" or 5.08mm) 4 Flying Wires Serial Number 001

Size 35mm DSLM

DINGS' DSLM Series in NEMA Size 14 [35mm] offers excellent linear speed and precise positioning performance.

Using spline slide rail as linear guide, it maximizes travel distance as max. 900mm stroke and ensures slider offset.

DSLm series offers teflon coating for longer life cycle and employs fixed half nut structure to drive the slide and provides stable structure.



Motor Characteristics

Motor	Voltage (V)	Current (A (RMS))	Resistance (Ω)	Inductance (mH)	Lead wire No.	Motor length (mm)
14E2105	6.6	0.5	13.2	14	4	33.6
14E2110	3.5	1.0	3.5	3.6	4	33.6
14E2115	2.7	1.5	1.8	1.9	4	33.6
14E2205	12.0	0.5	24.0	29	4	45.6
14E2210	6.0	1.0	6.0	7.2	4	45.6
14E2215	4.0	1.5	2.7	3.2	4	45.6

Available Lead Screw and Travel per Step

Screw Dia. (inch)	Screw Dia. (mm)	Lead (inch)	Lead (mm)	Lead Code	Travel Per Step @1.8° (mm)*
0.25	6.35	0.2	5.08	R	0.0254

Dimensional Drawings

Available Stroke Selection

Stroke (mm)	Base Length
50	126
100	176
150	226
200	276
250	326
300	376
350	426
400	476
450	526
500	576

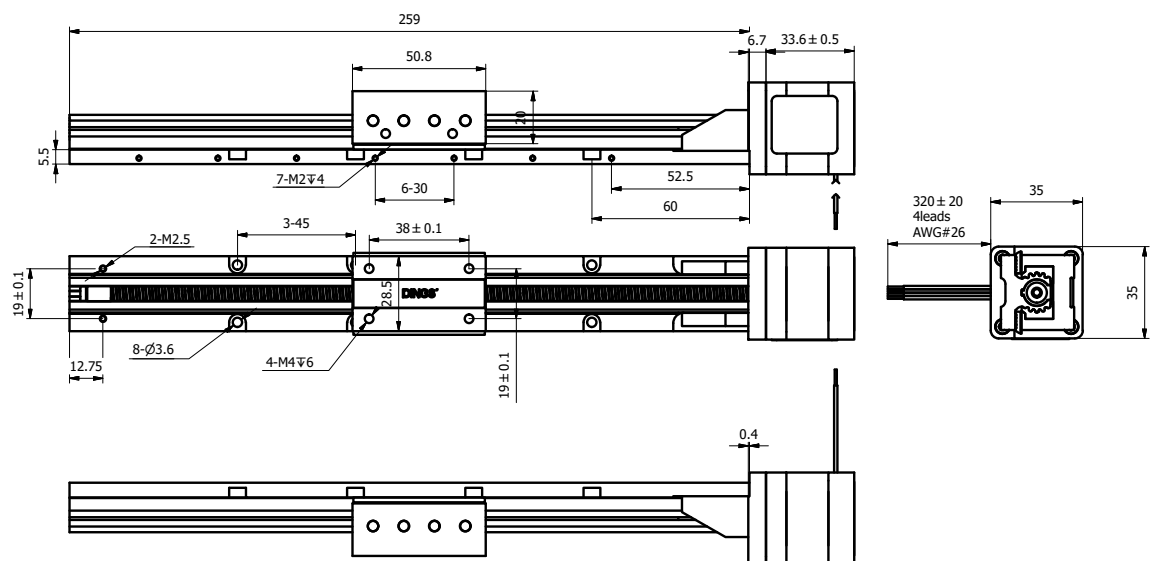

Size 42mm DSLM

DINGS' DSLM Series in NEMA Size 17 [42mm] offers excellent linear speed and precise positioning performance.

Using spline slide rail as linear guide, it maximizes travel distance as max. 900mm stroke and ensures slider offset.

DSLm series offers teflon coating for longer life cycle and employees fixed half nut structure to drive the slide and provides stable structure.



Motor Characteristics

Motor	Voltage (V)	Current (A (RMS))	Resistance (Ω)	Inductance (mH)	Lead wire No.	Motor length (mm)
17E2105	7.2	0.5	14.4	19.8	4	34.1
17E2110	3.8	1.0	3.8	5.0	4	34.1
17E2115	2.85	1.5	1.9	2.2	4	34.1
17E2205	11.0	0.5	22	46	4	48.1
17E2212	4.5	1.2	3.8	8.0	4	48.1
17E2225	2.5	2.5	1.0	1.8	4	48.1

Available Lead Screw and Travel per Step

Screw Dia. (inch)	Screw Dia. (mm)	Lead (inch)	Lead (mm)	Lead Code	Travel Per Step @1.8° (mm)*
0.25	6.35	0.2	5.08	R	0.0254

Dimensional Drawings

Available Stroke Selection

Stroke (mm)	Base Length
50	126
100	176
150	226
200	276
250	326
300	376
350	426
400	476
450	526
500	576

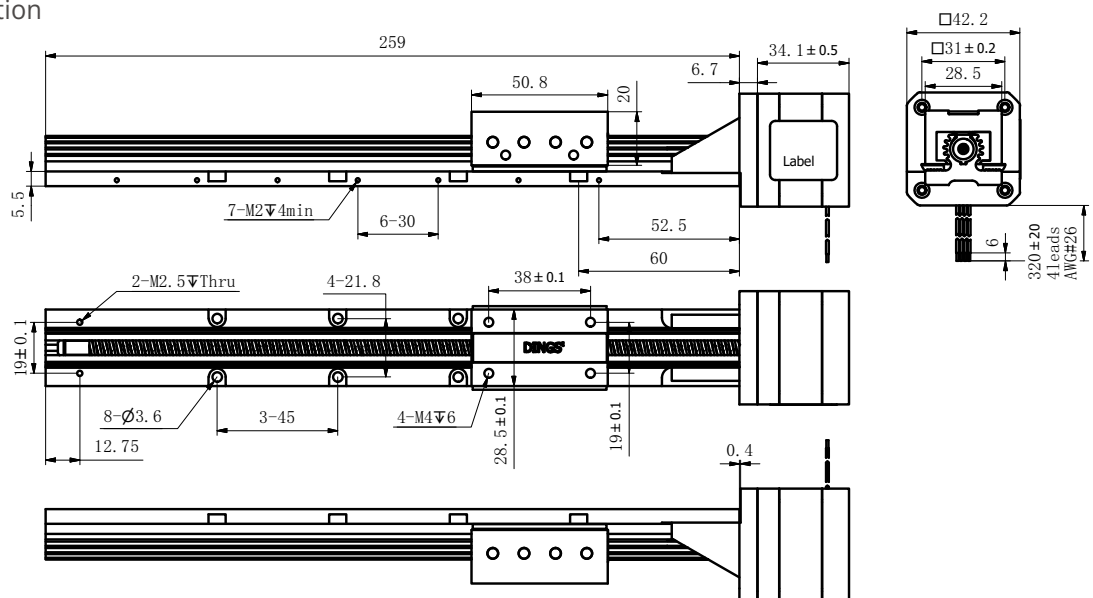

Since DSLM module adopts pure sliding friction, please refer to standard linear thrust force information and secure 1~2kg of margin in product selection.

Size 57mm DSLM

DINGS' DSLM Series in NEMA Size 23 [57mm] offers excellent linear speed and precise positioning performance.

Using spline slide rail as linear guide, it maximizes travel distance as max. 900mm stroke and ensures slider offset.

DSLm series offers teflon coating for longer life cycle and employees fixed half nut structure to drive the slide and provides stable structure.



Motor Characteristics

Motor	Voltage (V)	Current (A (RMS))	Resistance (Ω)	Inductance (mH)	Lead wire No.	Motor length (mm)
23E2110	6.4	1.0	6.4	16.4	4	45
23E2120	3.2	2.0	1.75	4.1	4	45
23E2130	2.4	3.0	0.8	1.7	4	45
23E2210	10.8	1.0	11.5	32	4	65
23E2225	4.2	2.5	2.0	5.2	4	65
23E2240	2.8	4.0	0.7	2.0	4	65

Available Lead Screw and Travel per Step

Screw Dia. (inch)	Screw Dia. (mm)	Lead (inch)	Lead (mm)	Lead Code	Travel Per Step @1.8° (mm)*
0.25	6.35	0.2	5.08	R	0.0254

Dimensional Drawings

Available Stroke Selection

Stroke (mm)	Base Length
50	126
100	176
150	226
200	276
250	326
300	376
350	426
400	476
450	526
500	576

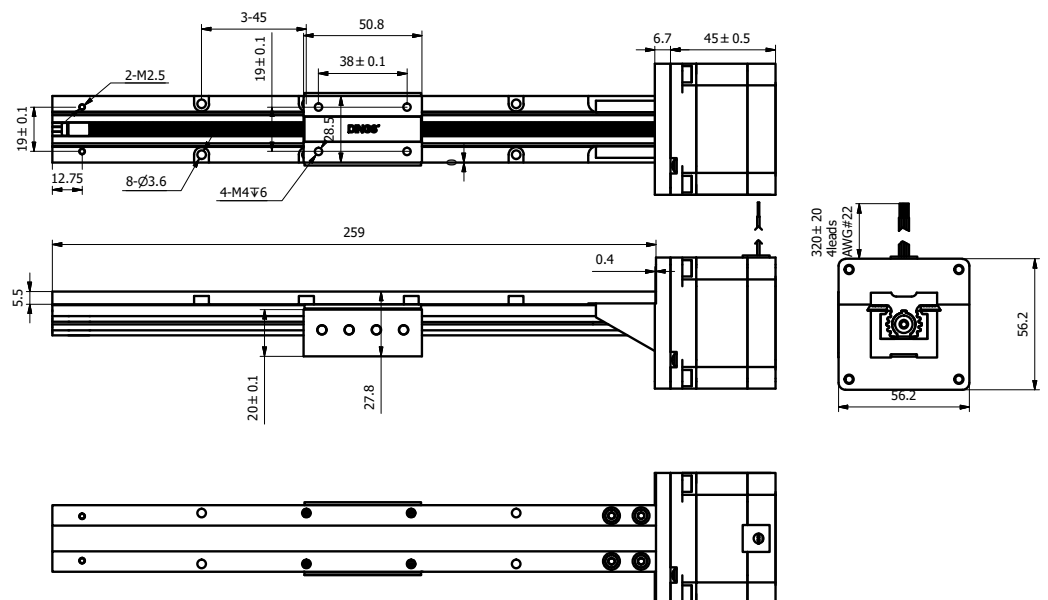

DINGS'

Precision Motion Specialist

Headquarter , CHINA

Jiangsu DINGS' Intelligent Control Technology Co., LTD

No.2850 Luheng Road, Changzhou Economic Development Zone, Jiangsu Province, China

Phone : +86-519-85177826

Fax : +86-519-85177807

E-mail : info@dingsmotion.com

www.dingsmotion.com

Shenzhen Office

Room 1105, Block C, CIMC industry demonstration park, Qiaoming Road, Guangming district, Shenzhen City

E-mail : info@dingsmotion.com

International Office

DINGS' Motion USA

355 Cochrane Circle Morgan Hill, CA 95037

Phone : +1-408-612-4970

E-mail : sales@dingsmotionusa.com

www.dingsmotionusa.com

DINGS' KOREA Co., Ltd

C-702, 158, Haneulmaeul-ro, Ilsandong-gu, Goyang-si, Gyeonggi-do, Republic of Korea

Phone : +82-31-994-0755

Fax : +82-70-4325-0755

E-mail : daniel@dingsmotion.com

www.dingsmotion.kr

DINGS' JAPAN

101, 2-27-18, Nishi-kojiya, Ota-ku, Tokyo 144-0034 JAPAN

Phone : +81-3-6811-1335

E-mail : tsukahara@dingsmotion.com

www.dingsmotion.com

- This catalog is the sole property of DINGS' and without the written authorization of DINGS', any copy or forwarding is prohibited.
- DINGS' reserves the right to make changes without further notification to any products herein to improve the reliability, function or design.
- DINGS' reserves the final interpretation.